



尺寸  
Size  
10 ~ 25



重量  
Weight  
80 ~ 600 g



開啓扭力  
Torque open  
0.19 ~ 2.73 Nm



張開角度  
Opening angle  
180°



適用工件重量  
Recom. workpiece weight  
0.06 ~ 0.85 KG



- 1 MGB 雙導桿氣缸模組  
MGB dual guide rod cylinder module
- 2 SRB 通用型旋轉氣缸模組  
SRB universal swivel unit
- 3 LGX 長行程小型二指平動機械夾爪  
LGX small long stroke 2-jaw parallel gripper
- 4 LGY 小原件180度張角式機械夾爪  
LGY small 180° angular gripper



## 應用領域

- 小型工件夾持，提供了自動化更多的應用方式。
- 自動化組裝線及插取件專用模組。
- 180度張開角度，能夾取更多的工件形式。
- 適用於機台製作或工廠生產、組裝及自動化產業的乾淨環境。

## 你的優勢

- 拉桿式設計：拉桿機構，能產生更多的力量。
- 適用於自動化組裝線。
- 空氣供給，確保在各式自動化系統中皆可彈性供給壓縮空氣。
- 夾持力安全裝置：搭配機械式外部SDV逆止閥。

## Applications

- Suitable for small workpiece clamping, provides more applications for automation.
- Great for automated assembly lines and special plug in and pick up modules.
- 180° opening angle, can handle several kinds of workpiece.
- Best for clean environment of machine production or factory production, assemble and automation industry.

## Your advantage

- Rod design: rod mechanism, can produce more power.
- Suitable for automated assembly lines.
- Air supply, ensure all kinds of automation systems can have elasticity supply of compressed air.
- Gripping force safety device: with mechanical external SDV pressure safety valve.

## LGY 系列簡介

- 工作原理：拉桿式設計
- 外殼材質：鋁合金，超硬陽極處理
- 基爪材質：鋼
- 驅動方式：氣動：濾清壓縮空氣 (10mm) - 乾式、潤滑或非潤滑壓力介質：需求壓縮空氣品質等級 DIN ISO 8573-1
- 保固：12個月
- 夾持力安全裝置：搭配機械式外部SDV逆止閥。

## LGY Series Introduction

- How it works: Rod design.
- Gripper material: Aluminum alloy, hard anodized.
- Jaw material: Steel
- Drive: Pneumatic-filtration of compressed air \_ (10mm) \_- dry, lubricated or non-lubricated pressure medium: demand for compressed air quality level DIN ISO 8573-1
- Warranty: 12 months.
- Gripping force safety device: with mechanical external SDV pressure safety valve.



**▶ LGY-10**



### 夾持力 Gripping force

夾持力與 夾爪 (finger) 長度對照表 Gripping force and jaw (finger) length chart

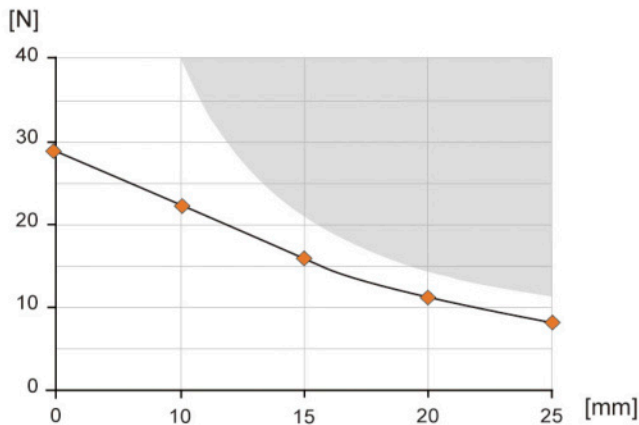

顏色區域：會增加夾爪磨損及撕裂機會

Colored area: increased wear and tear to be expected

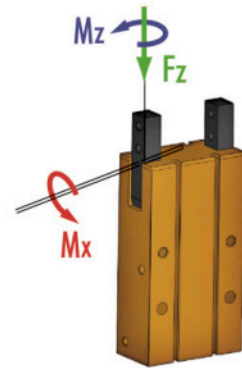

- Mx max. 0.32 Nm
- Mz max. 0.35 Nm
- Fz max. 17.0 N

### 技術資料 Technical data

型號 Model	LGY-10	
夾爪開張角度 Jaws opening angle	°	180°
夾爪關閉角度 Jaws closing angle	°	-3°
開啓扭力 Opening torque	Nm	0.19
關閉扭力 Closing torque	Nm	0.17
重量 Weight	g	80
建議工件重量 Recom. work piece weight	kg	0.05
最小/最大壓力 Min. / Max. pressure	bar	1 ~ 6
額定工作壓力 Nominal pressure	bar	6
關閉/開啓時間 Closing / opening time	s	0.02
夾爪長度可允許 Max. finger length	mm	25
夾爪重量可允許 Max. finger weight	kg	0.03
IP 等級 IP rating	IP	40
最小/最大室溫 Min. / Max. temperature	°C	-10° ~ 60°C
重複精度 Repeatability	mm	± 0.2

## 外觀尺寸圖 Dimensions

Technical drawings showing dimensions and features of the Small 180° Angular Gripper:

- Top View (配合固定槽圖):** Shows a width of 12 and 4-M3x0.5 holes.
- Side View:** Shows a length of 30, 2-M3x0.5x4 holes, and a diameter of 9.
- Front View:** Shows a total length of 71, with various sub-lengths (22, 23.5, 18, 35, 47.5, 58) and diameters (4, 24). It includes 2-M3x0.5x6 holes (固定用螺絲) and 2-φ3.4 holes (固定用孔).
- Bottom View:** Shows a diameter of 15, 2-M3x0.5x6 holes (固定用螺絲), a position-determining pin hole (位置決定插銷孔), and a hole with dimensions  $\phi 11^{+0.043} \times 1.5$  mm.
- Detail View:** Shows M5x0.8 holes labeled A and B, with a distance of 23 between them and a 7 mm offset from the edge.
- Sensor Groove Detail:** Shows a groove with a diameter of  $\phi 4.1$  and a depth of 13.

**Legend:**

- A 孔:** 主連接孔，夾爪開啓。  
**B 孔:** 主連接孔，夾爪閉合。
- ① 機械手，連接介面。**
- ② 夾爪連接介面。**
- A Hole:** main connection, gripper open
- B Hole:** main connection, gripper close
- ① Robot, connection interface**
- ② Gripper connection interface**

LGY-10

## (接觸式)C型槽感應器系統 (Contact) C-slot sensor system

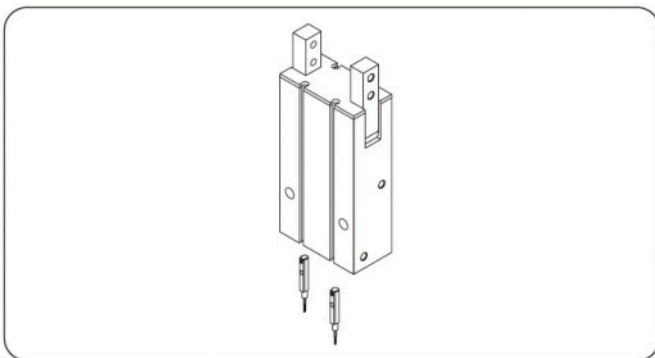

- 接觸式C型槽終端位置監控: 夾爪磁簧感應器，安裝於夾爪C型槽內。
- 每個機械夾爪需要至少2個感應器(接觸式)。
- Contact C-slot terminal position monitoring: Gripper magnetic field sensor, installed in the C-slot.
- Each mechanical gripper needs at least two sensors (contact).

型號 Model	型式 Description	建議使用數量 Recom. number of use
MMS-30	直行設計(兩線無接點) Straight design (two-line non-contact)	2

## 夾爪調速閥 Speed control valve

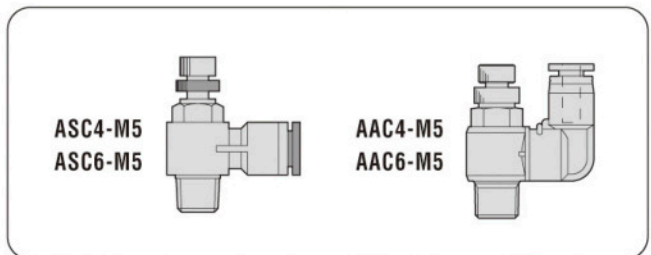

- 夾爪專用調速閥: 調整夾爪開張速度專用調速閥門。
- 每個機械夾爪需要至少2個調速閥。
- Speed control valve special for grippers: Special for adjusting the opening speed of gripper.
- Each mechanical gripper needs at least two speed control valves.

型號 Model	型式 Description	建議使用數量 Recom. number of use
ASC4-M5	90度設計 Ø4管徑 90 degrees design ø4 diameter	2
AAC6-M5	直通設計 Ø6管徑 Through design ø6 diameter	2
ASC4-M5	90度設計 Ø4管徑 90 degrees design ø4 diameter	2
AAC6-M5	直通設計 Ø6管徑 Through design ø6 diameter	2

### ▶ LGY-16



#### 夾持力 Gripping force

夾持力與 夾爪 (finger) 長度對照表 Gripping force and jaw (finger) length chart

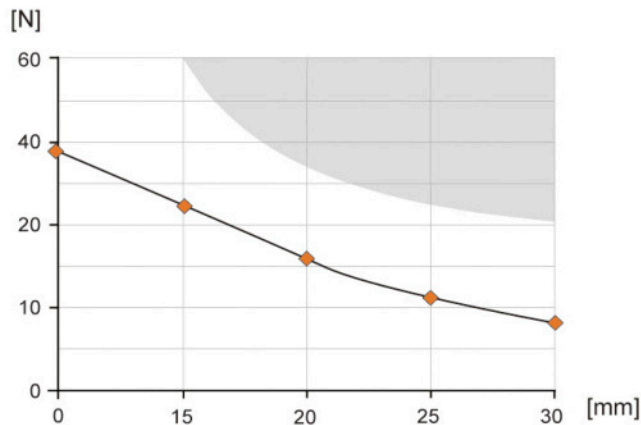

顏色區域：會增加夾爪磨損及撕裂機會

Colored area: increased wear and tear to be expected

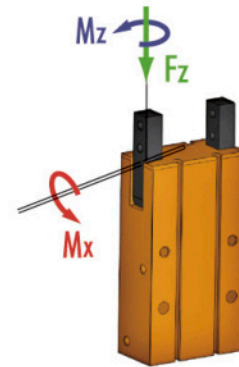

- Mx max. 0.70 Nm
- Mz max. 0.80 Nm
- Fz max. 31.0 N

#### 技術資料 Technical data

型號 Model	LGY-16	
夾爪開張角度 Jaws opening angle	°	180°
夾爪關閉角度 Jaws closing angle	°	-3°
開啓扭力 Opening torque	Nm	0.64
關閉扭力 Closing torque	Nm	0.58
重量 Weight	g	150
建議工件重量 Recom. work piece weight	kg	0.12
最小/最大壓力 Min. / Max. pressure	bar	1 ~ 6
額定工作壓力 Nominal pressure	bar	6
關閉/開啓時間 Closing / opening time	s	0.02
夾爪長度可允許 Max. finger length	mm	35
夾爪重量可允許 Max. finger weight	kg	0.04
IP 等級 IP rating	IP	40
最小/最大室溫 Min. / Max. temperature	°C	-10° ~ 60°C
重複精度 Repeatability	mm	± 0.2

# Small 180° Angular Gripper

## 外觀尺寸圖 Dimensions

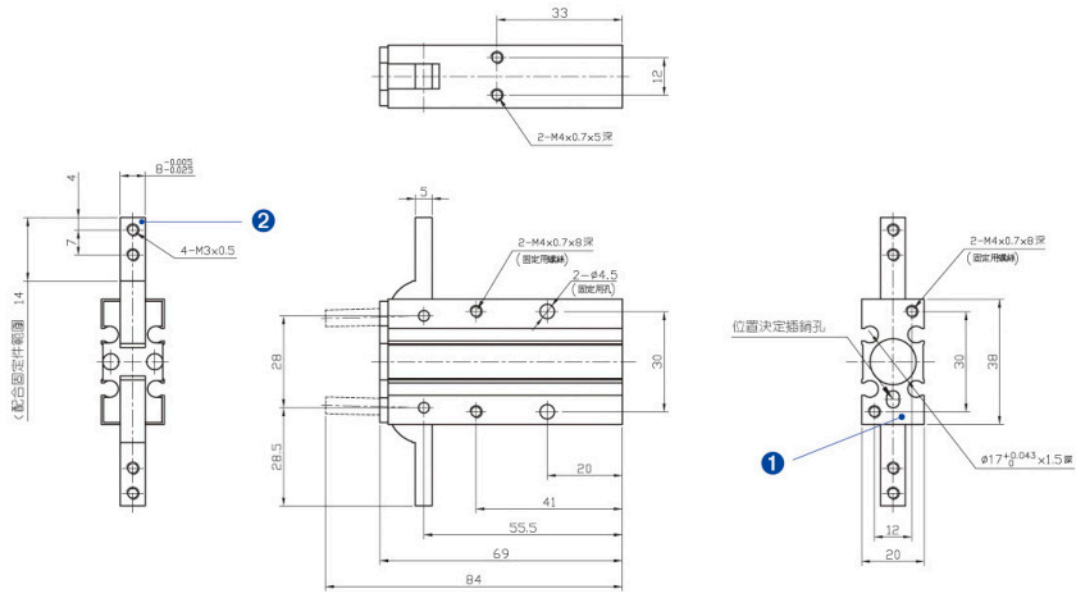

- A 孔：主連接孔，夾爪開啓。
- B 孔：主連接孔，夾爪閉合。
- ① 機械手，連接介面。
- ② 夾爪連接介面。
- A Hole: main connection, gripper open
- B Hole: main connection, gripper close
- ① Robot, connection interface
- ② Gripper connection interface

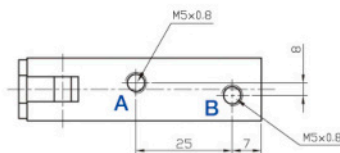

感應開關固定溝槽

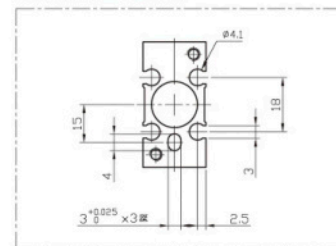

## (接觸式)C型槽感應器系統 (Contact) C-slot sensor system

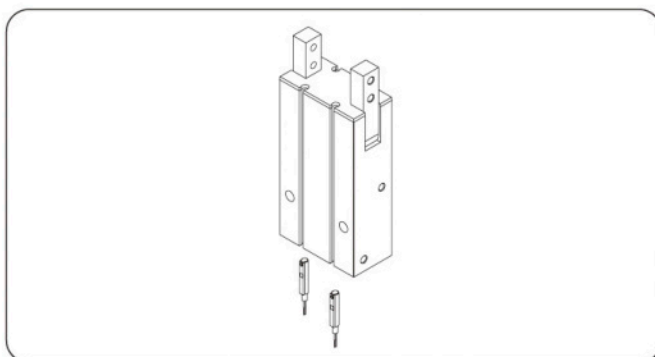

- 接觸式C型槽終端位置監控:夾爪磁簧感應器，安裝於夾爪C型槽內。
- 每個機械夾爪需要至少要2個感應器(接觸式)。
- Contact C-slot terminal position monitoring: Gripper magnetic field sensor, installed in the C-slot.
- Each mechanical gripper needs at least two sensors (contact).

型號 Model	型式 Description	建議使用數量 Recom. number of use
MMS-30	直行設計(兩線無接點) Straight design (two-line non-contact)	2

## 夾爪調速閥 Speed control valve

ASC4-M5  
ASC6-M5

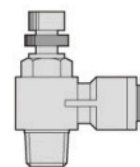

AAC4-M5  
AAC6-M5

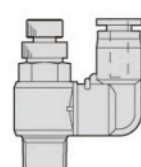

- 夾爪專用調速閥: 調整夾爪開張速度專用調速閥門。
- 每個機械夾爪需要至少要2個調速閥。
- Speed control valve special for grippers: Special for adjusting the opening speed of gripper.
- Each mechanical gripper needs at least two speed control valves.

型號 Model	型式 Description	建議使用數量 Recom. number of use
ASC4-M5	90度設計 Ø4管徑 90 degrees design ø4 diameter	2
AAC6-M5	直通設計 Ø6管徑 Through design ø6 diameter	2
ASC4-M5	90度設計 Ø4管徑 90 degrees design ø4 diameter	2
AAC6-M5	直通設計 Ø6管徑 Through design ø6 diameter	2

**▶ LGY-20**



### 夾持力 Gripping force

夾持力與 夾爪 (finger) 長度對照表 Gripping force and jaw (finger) length chart

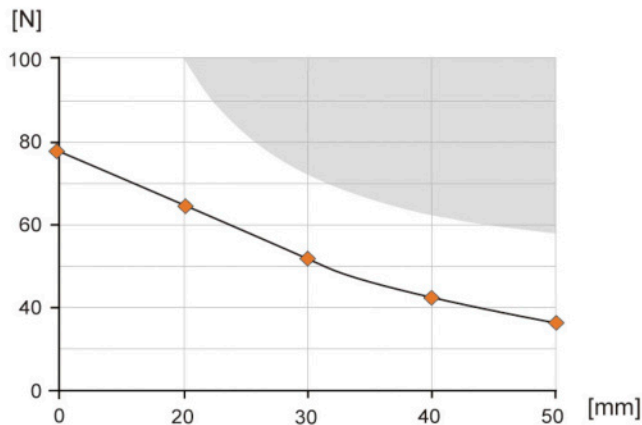

顏色區域：會增加夾爪磨損及撕裂機會

Colored area: increased wear and tear to be expected

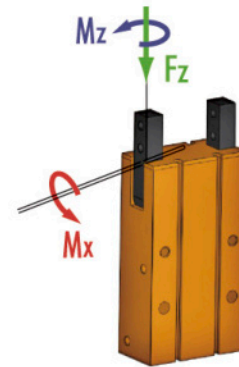

- Mx max. 1.36 Nm
- Mz max. 1.25 Nm
- Fz max. 42.0 N

### 技術資料 Technical data

型號 Model	LGY-20	
夾爪開張角度 Jaws opening angle	°	180°
夾爪關閉角度 Jaws closing angle	°	-3°
開啓扭力 Opening torque	Nm	1.32
關閉扭力 Closing torque	Nm	1.21
重量 Weight	g	320
建議工件重量 Recom. work piece weight	kg	0.21
最小/最大壓力 Min. / Max. pressure	bar	1 ~ 6
額定工作壓力 Nominal pressure	bar	6
關閉/開啓時間 Closing / opening time	s	0.02
夾爪長度可允許 Max. finger length	mm	50
夾爪重量可允許 Max. finger weight	kg	0.55
IP 等級 IP rating	IP	40
最小/最大室溫 Min. / Max. temperature	°C	-10° ~ 60°C
重複精度 Repeatability	mm	± 0.2

# Small 180° Angular Gripper

## 外觀尺寸圖 Dimensions

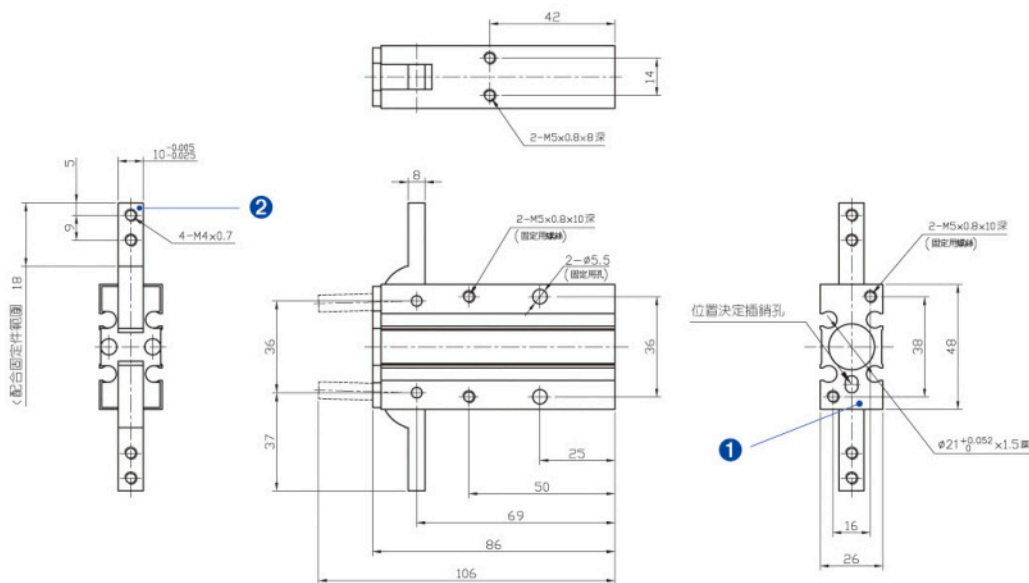

- A 孔：主連接孔，夾爪開啓。
- B 孔：主連接孔，夾爪閉合。
- ① 機械手，連接介面。
- ② 夾爪連接介面。
- A Hole: main connection, gripper open
- B Hole: main connection, gripper close
- ① Robot, connection interface
- ② Gripper connection interface

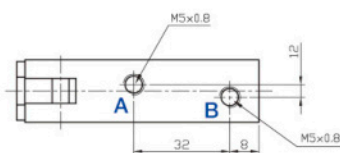

感應開關固定溝槽

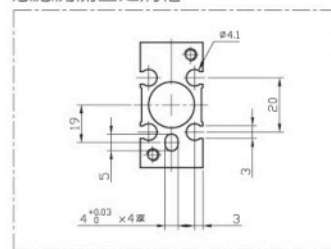

## (接觸式)C型槽感應器系統 (Contact) C-slot sensor system

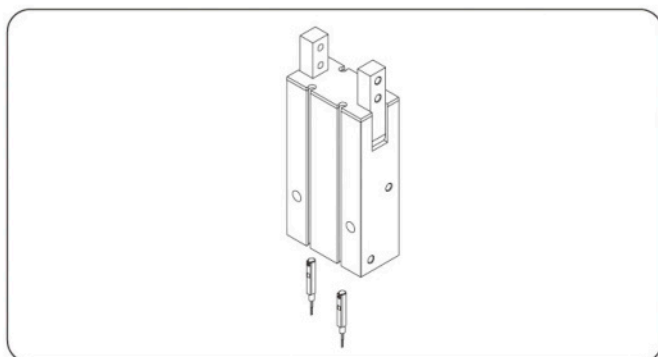

- 接觸式C型槽終端位置監控:夾爪磁簧感應器，安裝於夾爪C型槽內。
- 每個機械夾爪需要至少要2個感應器(接觸式)。
- Contact C-slot terminal position monitoring: Gripper magnetic field sensor, installed in the C-slot.
- Each mechanical gripper needs at least two sensors (contact).

型號 Model	型式 Description	建議使用數量 Recom. number of use
MMS-30	直行設計(兩線無接點) Straight design (two-line non-contact)	2

## 夾爪調速閥 Speed control valve

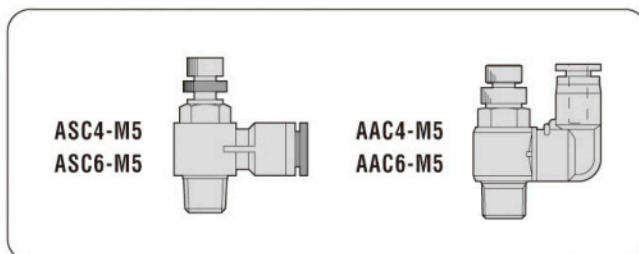

- 夾爪專用調速閥: 調整夾爪開張速度專用調速閥門。
- 每個機械夾爪需要至少要2個調速閥。
- Speed control valve special for grippers: Special for adjusting the opening speed of gripper.
- Each mechanical gripper needs at least two speed control valves.

型號 Model	型式 Description	建議使用數量 Recom. number of use
ASC4-M5	90度設計 Ø4管徑 90 degrees design ø4 diameter	2
AAC6-M5	直通設計 Ø6管徑 Through design ø6 diameter	2
ASC4-M5	90度設計 Ø4管徑 90 degrees design ø4 diameter	2
AAC6-M5	直通設計 Ø6管徑 Through design ø6 diameter	2

LGY-20



**▶ LGY-25**



### 夾持力 Gripping force

夾持力與 夾爪 (finger) 長度對照表 Gripping force and jaw (finger) length chart

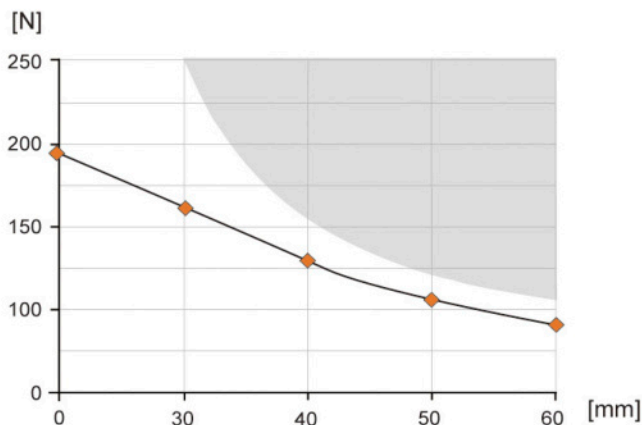

顏色區域：會增加夾爪磨損及撕裂機會

Colored area: increased wear and tear to be expected

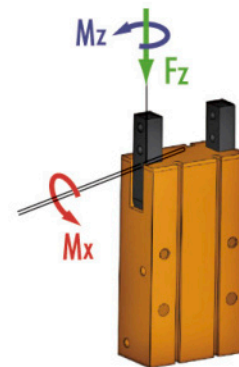

- Mx max. 2.88 Nm
- Mz max. 2.00 Nm
- Fz max. 45.0 N

### 技術資料 Technical data

型號 Model	LGY-25	
夾爪開張角度 Jaws opening angle	°	180°
夾爪關閉角度 Jaws closing angle	°	-3°
開啓扭力 Opening torque	Nm	2.736
關閉扭力 Closing torque	Nm	2.62
重量 Weight	g	600
建議工件重量 Recom. work piece weight	kg	0.32
最小/最大壓力 Min. / Max. pressure	bar	1 ~ 6
額定工作壓力 Nominal pressure	bar	6
關閉/開啓時間 Closing / opening time	s	0.02
夾爪長度可允許 Max. finger length	mm	60
夾爪重量可允許 Max. finger weight	kg	0.65
IP 等級 IP rating	IP	40
最小/最大室溫 Min. / Max. temperature	°C	-10° ~ 60°C
重複精度 Repeatability	mm	± 0.2

## 外觀尺寸圖 Dimensions

**A 孔**：主連接孔，夾爪開啓。  
**B 孔**：主連接孔，夾爪閉合。  
**①** 機械手，連接介面。  
**②** 夾爪連接介面。

**A Hole**: main connection, gripper open  
**B Hole**: main connection, gripper close  
**①** Robot, connection interface  
**②** Gripper connection interface

感應開關固定溝槽

LGY-25

## (接觸式)C型槽感應器系統 (Contact) C-slot sensor system

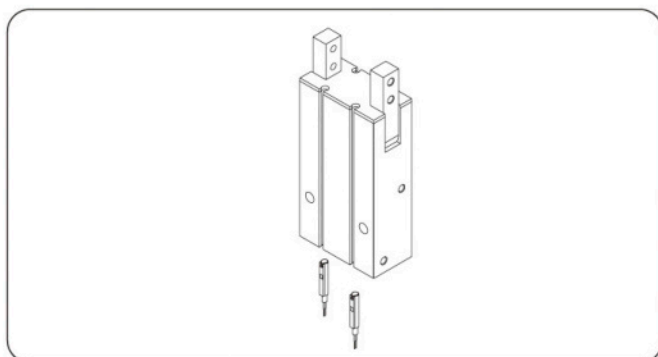

- 接觸式C型槽終端位置監控:夾爪磁簧感應器，安裝於夾爪C型槽內。
- 每個機械夾爪需要至少2個感應器(接觸式)。
- Contact C-slot terminal position monitoring: Gripper magnetic field sensor, installed in the C-slot.
- Each mechanical gripper needs at least two sensors (contact).

型號 Model	型式 Description	建議使用數量 Recom. number of use
MMS-30	直行設計(兩線無接點) Straight design (two-line non-contact)	2

## 夾爪調速閥 Speed control valve

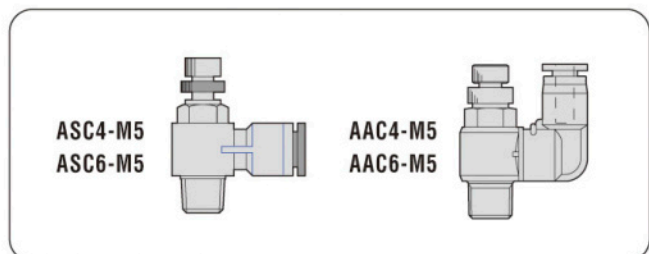

- 夾爪專用調速閥: 調整夾爪開張速度專用調速閥門。
- 每個機械夾爪需要至少2個調速閥。
- Speed control valve special for grippers: Special for adjusting the opening speed of gripper.
- Each mechanical gripper needs at least two speed control valves.

型號 Model	型式 Description	建議使用數量 Recom. number of use
ASC4-M5	90度設計 Ø4管徑 90 degrees design ø4 diameter	2
AAC6-M5	直通設計 Ø6管徑 Through design ø6 diameter	2
ASC4-M5	90度設計 Ø4管徑 90 degrees design ø4 diameter	2
AAC6-M5	直通設計 Ø6管徑 Through design ø6 diameter	2