

### RGN-plus 50

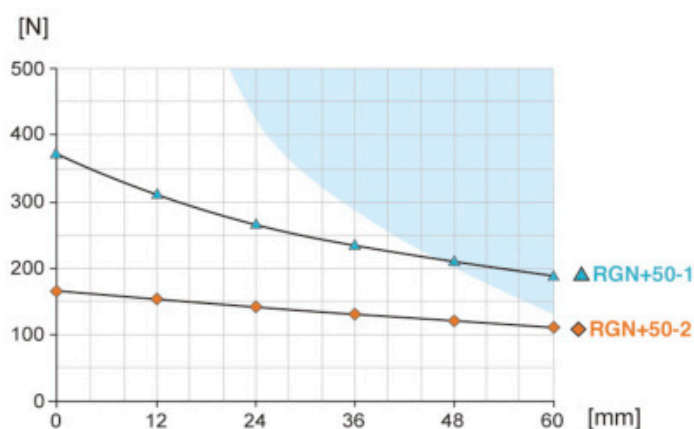

#### 夾持力 Gripping force

夾持力與 夾爪 (finger) 長度對照表 Gripping force and jaw (finger) length chart



顏色區域：會增加夾爪磨損及撕裂機會

Colored area: increased wear and tear to be expected

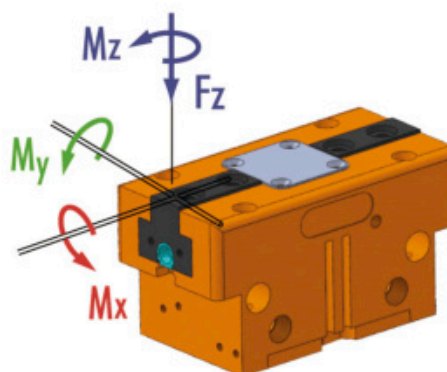

- Mx max. 15.0 Nm
- My max. 15.0 Nm
- Mz max. 8.0 Nm
- Fz max. 700.0 N

#### 技術資料 Technical data

型號 Model		RGN+50-1	RGN+50-2
單爪行程 Stroke per jaw	mm	4	2
關閉力 Closing force	N	170	375
開啓力 Opening force	N	185	410
關閉/開啓時間 Closing/opening Time	s	0.02 / 0.02	0.02 / 0.02
重複精度 Repeatability	+/- mm	0.01	0.01
最小壓力 Min. pressure	bar	3	3
最大壓力 Max. pressure	bar	8	8
最小/最大溫度 Min. /max. temperature	°C	5 - 80	5 - 80
壓縮空氣消耗量 Compressed air consumption	cm <sup>3</sup>	4.1	4.1
重量 Weight	Kg	0.14	0.14
建議工件重量 Recom. work piece weight	Kg	0.85	1.8

# Classic 2-Jaw Parallel Gripper

## 外觀尺寸圖 Dimensions

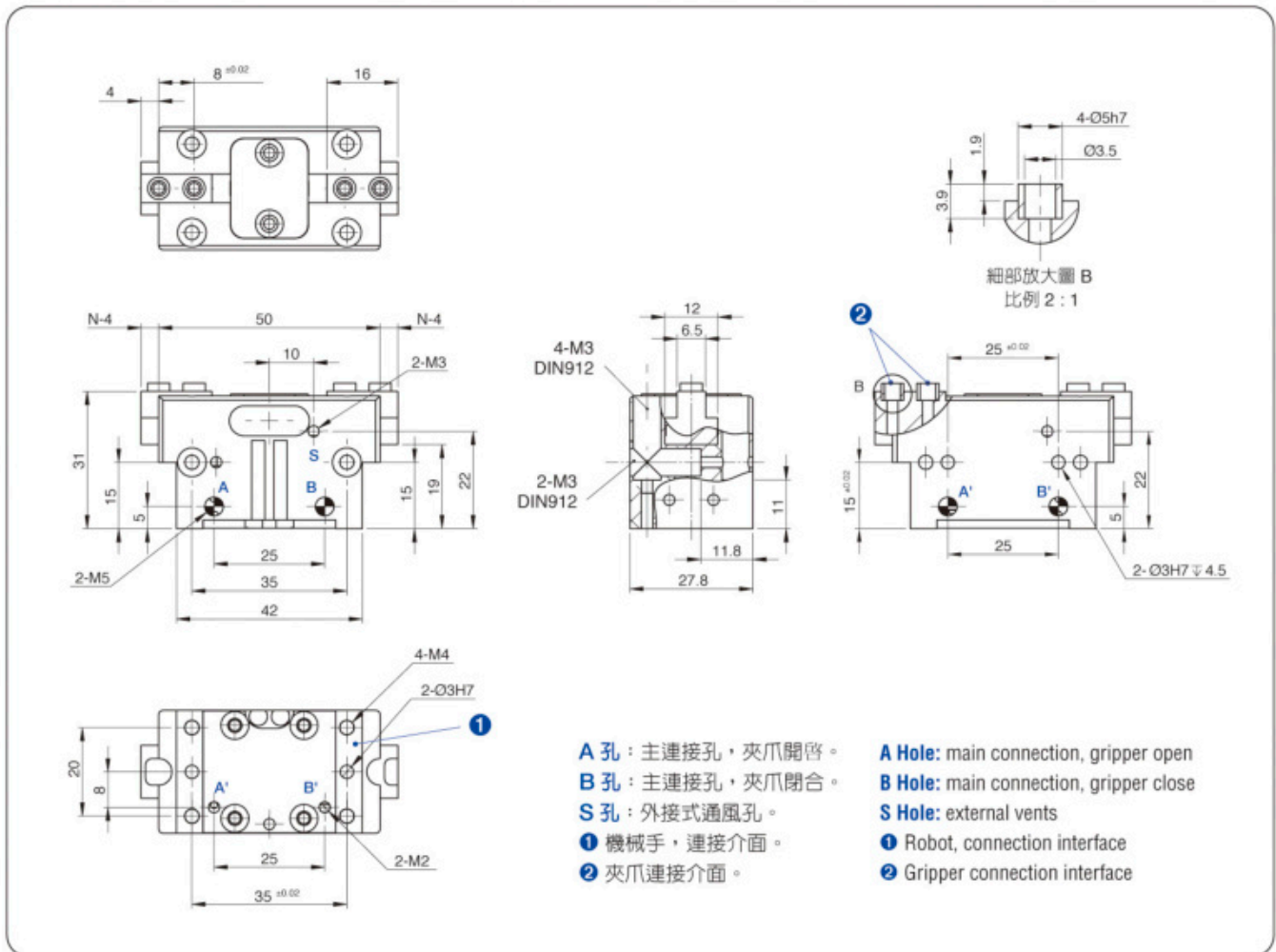

■ 上圖為閉爪時的基本款，不含選配物件尺寸。 ■ The picture shows the basic models when closing, excluding optional object size.

## 背板供氣示意圖 Hose-free direct connection

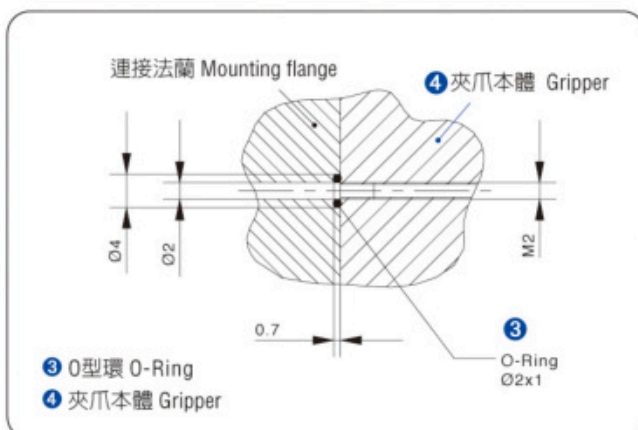

- 直接連結供氣口，壓縮空氣直接供給夾爪使用，無須外接管線，可將壓力介質饋入安裝板上的內孔。
- Direct link air supply port, compressed air supplied directly to the jaws, no external piping, pressure medium can be fed into the hole on the mounting plate

## 求心襯套尺寸圖 Centering sleeve

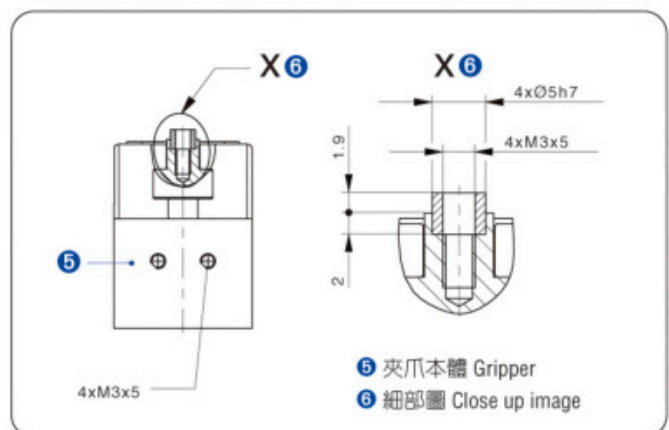

- 使用求心襯套來固定機械手指，達到準確定位。
- Using centering sleeve to fix the mechanical fingers, to achieve accurate positioning.

### (無接觸式)側邊感應器系統 (Non-contact) Side sensor system

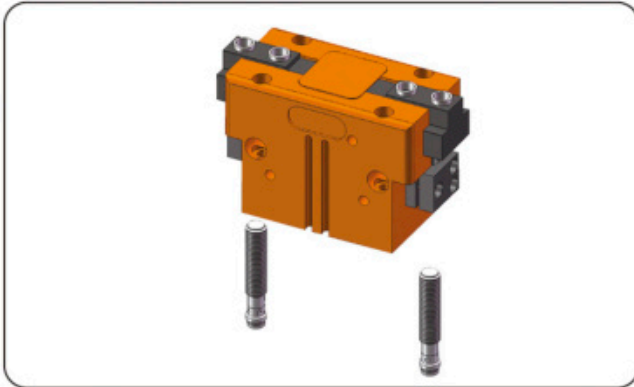

- (無接觸式)側邊終端位置監控:  
夾爪行程感應器，可直接由側邊安裝。
- 每個機械夾爪需要至少需要2個感應器(無接觸式)。
- (Non-contact) Side terminal position monitoring:  
Jaw stroke sensor can be installed directly from the sides.
- Each mechanical gripper needs at least two sensors (non-contact)

型號 Model	建議使用數量 Recom. number of use
IN80-M8	2

### (接觸式)C型槽感應器系統 (Contact) C-slot sensor system

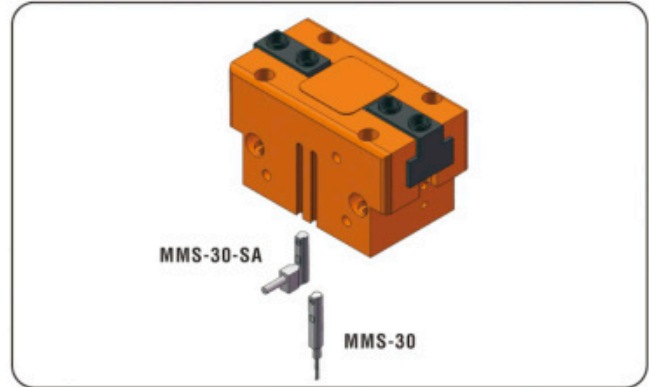

- 接觸式C型槽終端位置監控:  
夾爪磁簧感應器，安裝於夾爪C型槽內。
- 每個機械夾爪需要至少需要2個感應器(接觸式)。
- Contact C-slot terminal position monitoring:  
Gripper magnetic field sensor, installed in the C-slot.
- Each mechanical gripper needs at least two sensors (contact)

型號 Model	型式 Description	建議使用數量 Recom. number of use
MMS-30	直行設計(兩線無接點) Straight design (two-line non-contact)	2
MMS-30-SA	90度設計(兩線無接點) 90 degrees design (two-line non-contact)	2

### 夾爪素材 Universal jaw set

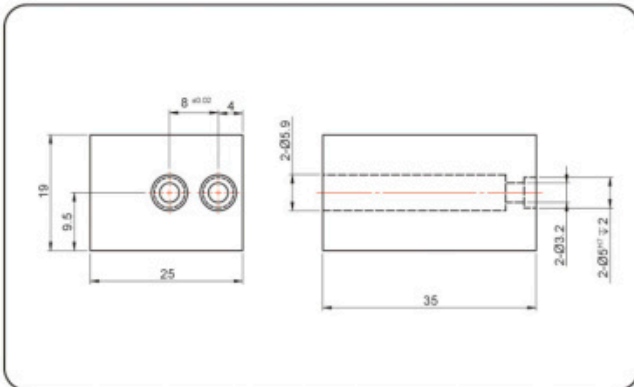

- 素材夾爪供客戶自行加工，螺絲連接介面也需自行加工。
- Jaw sets are provided for customer self-processing, screw connection interface also need their own processing.

型號 Model	材質 Description	建議使用數量 Recom. number of use
ABR-plus 50	鋁 Aluminium	2
SBR-plus 50	鐵 Iron	2

### 防塵罩模組 Dust protection module

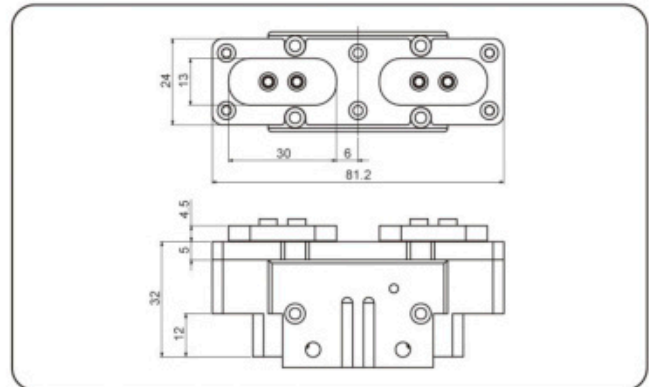

- 安裝螺絲連接介面，請見基本款。
- 防塵保護款增加了防止滲透性物質進入的等級  
夾爪長度需從防塵罩上的連接面量起。
- Mounting screw connection interface, see basic models.
- Dust protection is to upgrade the IP level and prevent from leaking materials into the gripper. The length of fingers need to be measured from the surface of dust cover.

型號 Model	材質 Description	建議使用數量 Recom. number of use
RGN+50-1-SD	鋁 Aluminium	1

## 夾爪最大可允許偏心率 Max permissible centrifugal degree

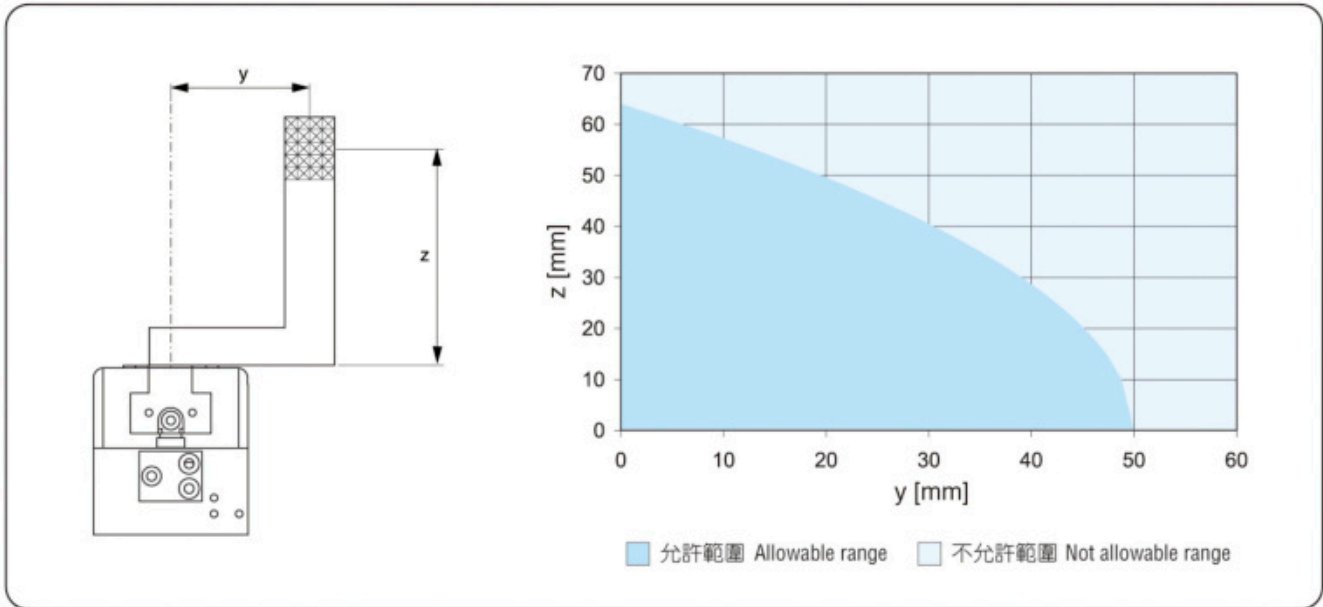

- 以上曲線圖適用於基本款(行程-1夾爪本體)。
- The graph above applies to basic models (stroke -1 jaws body)

## 夾爪調速閥 Speed control valve

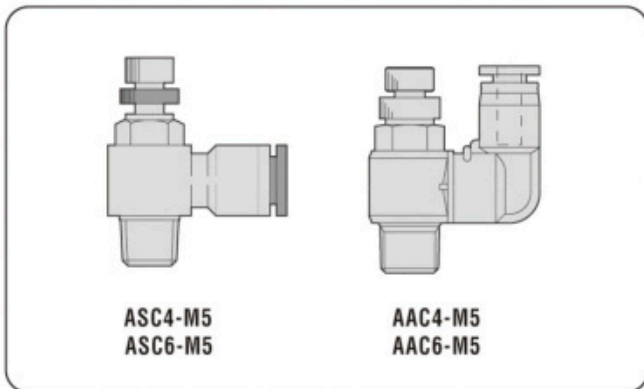

- 夾爪專用調速閥：  
調整夾爪開張速度專用調速閥門
- 每個機械夾爪需要至少要2個調速閥。

- Speed control valve special for grippers:  
Special for adjusting the opening speed of gripper.
- Each mechanical gripper needs at least two speed control valves.

型號	型式	建議使用數量
ASC4-M5	90度設計 Ø4管徑	2
ASC6-M5	90度設計 Ø6管徑	2
AAC4-M5	直通設計 Ø4管徑	2
AAC6-M5	直通設計 Ø6管徑	2

Model	Description	Recom. number of use
ASC4-M5	90 degrees design ø4 diameter	2
ASC6-M5	90 degrees design ø6 diameter	2
AAC4-M5	Straight design ø4 diameter	2
AAC6-M5	Straight design ø6 diameter	2

### RGN-plus 66



#### 夾持力 Gripping force

夾持力與 夾爪 (finger) 長度對照表 Gripping force and jaw (finger) length chart

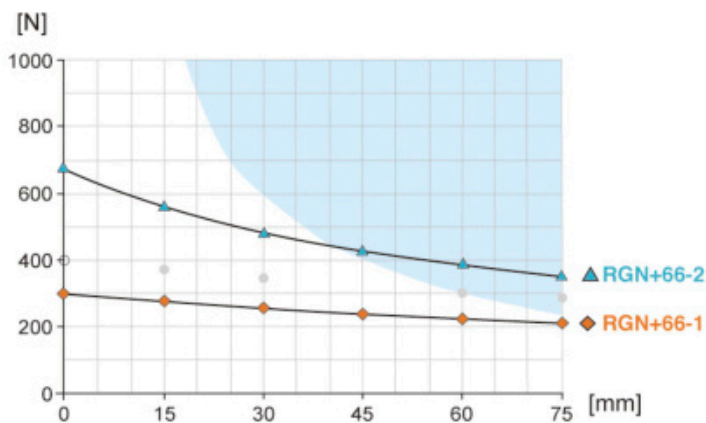

顏色區域：會增加夾爪磨損及撕裂機會  
Colored area: increased wear and tear to be expected

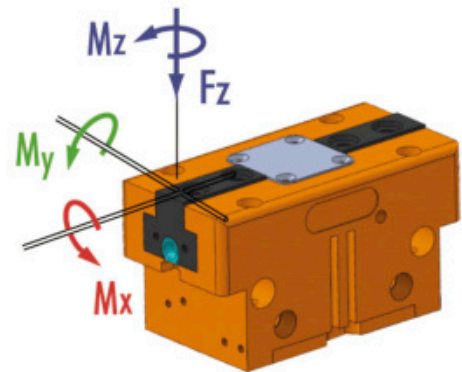

- Mx max. 50.0 Nm
- My max. 45.0 Nm
- Mz max. 35.0 Nm
- Fz max. 1200.0 N

#### 技術資料 Technical data

型號 Model		RGN+66-1	RGN+66-2
單爪行程 Stroke per jaw	mm	6	3
關閉力 Closing force	N	300	670
開啓力 Opening force	N	325	725
關閉/開啓時間 Closing/opening Time	s	0.03 / 0.03	0.03 / 0.03
重複精度 Repeatability	+/- mm	0.01	0.01
最小壓力 Min. pressure	bar	3	3
最大壓力 Max. pressure	bar	8	8
最小/最大溫度 Min. /max. temperature	°C	5 - 80	5 - 80
壓縮空氣消耗量 Compressed air consumption	cm <sup>3</sup>	10.1	10.1
重量 Weight	Kg	0.27	0.27
建議工件重量 Recom. work piece weight	Kg	1.4	3.2

# Classic 2-Jaw Parallel Gripper

## 外觀尺寸圖 Dimensions

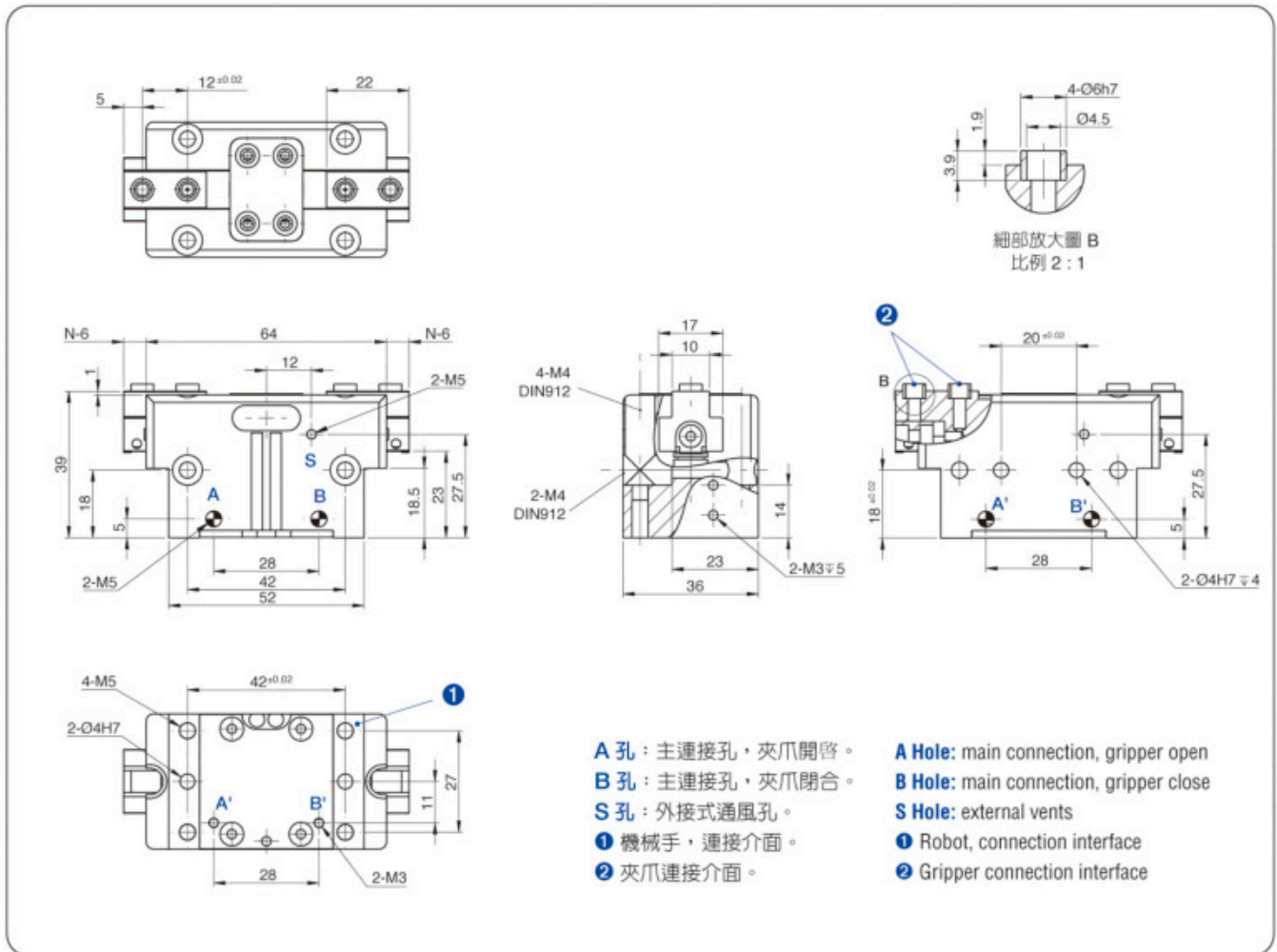

■ 上圖為閉爪時的基本款，不含選配物件尺寸。 ■ The picture shows the basic models when closing, excluding optional object size.

## 背板供氣示意圖 Hose-free direct connection

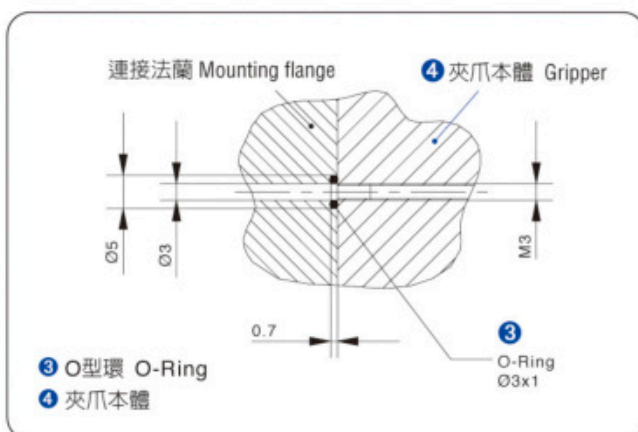

- 直接連結供氣口，壓縮空氣直接供給夾爪使用，無須外接管線，可將壓力介質饋入安裝板上的內孔。
- Direct link air supply port, compressed air supplied directly to the jaws, no external piping, pressure medium can be fed into the hole on the mounting plate

## 求心襯套尺寸圖 Centering sleeve

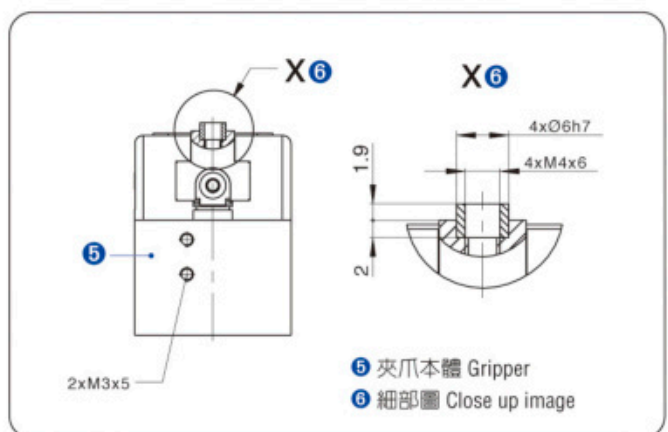

- 使用求心襯套來固定機械手指，達到準確定位。
- Using centering sleeve to fix the mechanical fingers, to achieve accurate positioning.

### (無接觸式)側邊感應器系統 (Non-contact) Side sensor system

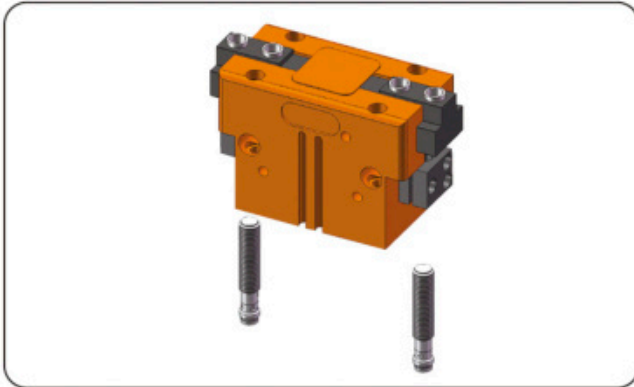

- (無接觸式)側邊終端位置監控:  
夾爪行程感應器,可直接由側邊安裝。
- 每個機械夾爪需要至少需要2個感應器(無接觸式)。
- (Non-contact) Side terminal position monitoring:  
Jaw stroke sensor can be installed directly from the sides.
- Each mechanical gripper needs at least two sensors (non-contact)

型號 Model	建議使用數量 Recom. number of use
IN80-M8	2

### (接觸式)C型槽感應器系統 (Contact) C-slot sensor system



- 接觸式C型槽終端位置監控:  
夾爪磁簧感應器,安裝於夾爪C型槽內。
- 每個機械夾爪需要至少需要2個感應器(接觸式)。
- Contact C-slot terminal position monitoring:  
Gripper magnetic field sensor, installed in the C-slot.
- Each mechanical gripper needs at least two sensors (contact)

型號 Model	型式 Description	建議使用數量 Recom. number of use
MMS-30	直行設計(兩線無接點) Straight design (two-line non-contact)	2
MMS-30-SA	90度設計(兩線無接點) 90 degrees design (two-line non-contact)	2

### 夾爪素材 Universal jaw set

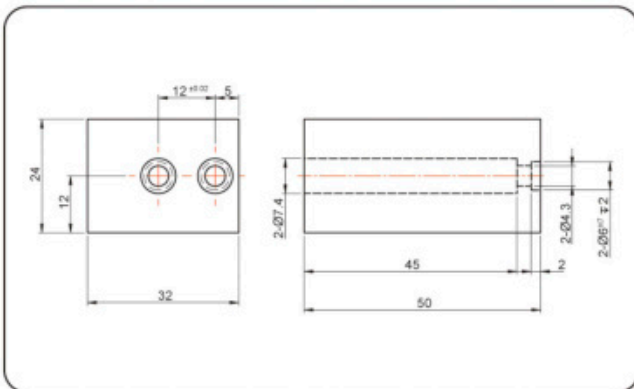

- 素材夾爪供客戶自行加工,螺絲連接介面也需自行加工。
- Jaw sets are provided for customer self-processing, screw connection interface also need their own processing.

型號 Model	材質 Description	建議使用數量 Recom. number of use
ABR-plus 66	鋁 Aluminium	2
SBR-plus 66	鐵 Iron	2

### 防塵罩模組 Dust protection module

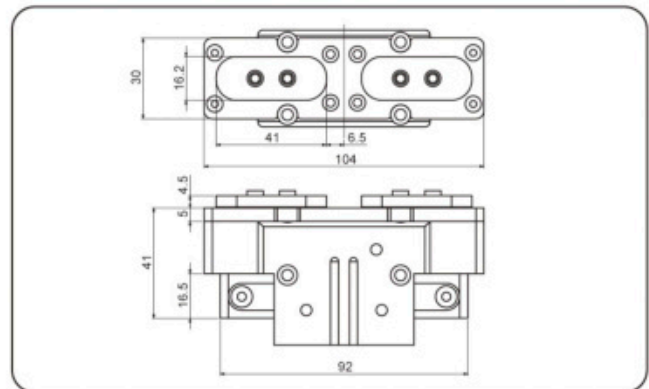

- 安裝螺絲連接介面,請見基本款。
- 防塵保護款增加了防止滲透性物質進入的等級  
夾爪長度需從防塵罩上的連接面量起。
- Mounting screw connection interface, see basic models.
- Dust protection is to upgrade the IP level and prevent from leaking materials into the gripper. The length of fingers need to be measured from the surface of dust cover.

型號 Model	材質 Description	建議使用數量 Recom. number of use
RGN+66-1-SD	鋁 Aluminium	1

## 夾爪最大可允許偏心率 Max permissible centrifugal degree

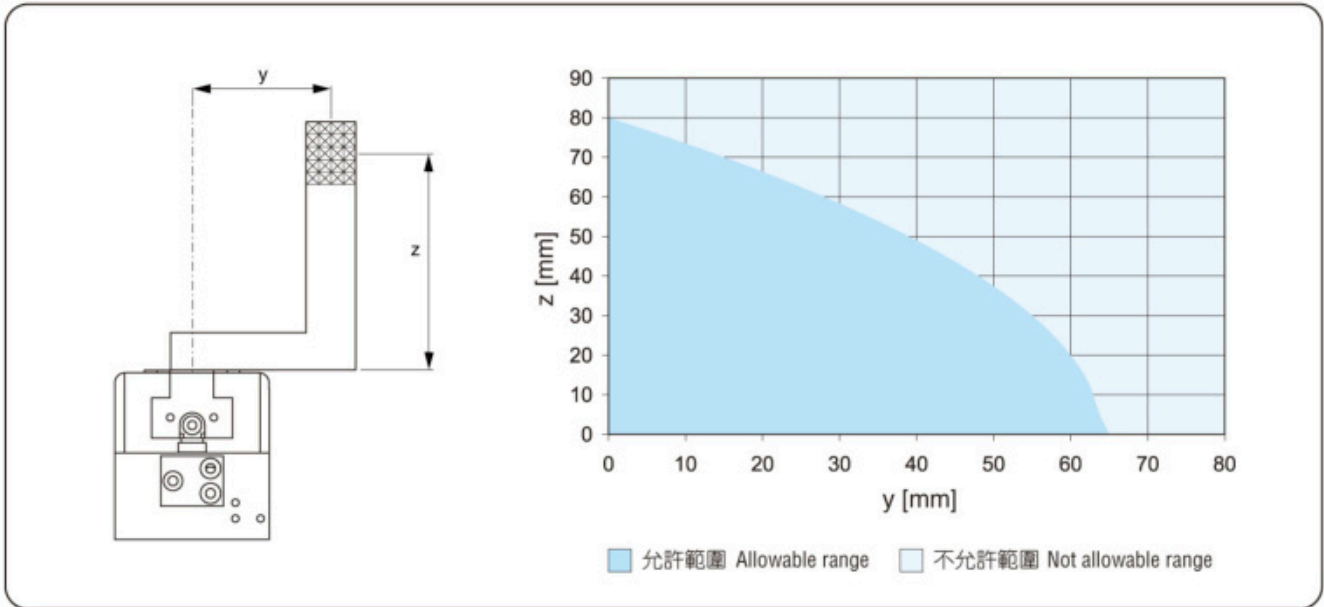

- 以上曲線圖適用於基本款(行程-1夾爪本體)。
- The graph above applies to basic models (stroke -1 jaws body)

## 夾爪調速閥 Speed control valve

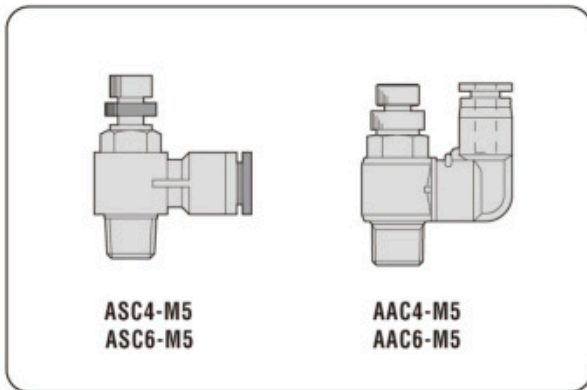

- 夾爪專用調速閥：  
調整夾爪開張速度專用調速閥門
- 每個機械夾爪需要至少2個調速閥。
- Speed control valve special for grippers:  
Special for adjusting the opening speed of gripper.
- Each mechanical gripper needs at least two speed control valves.

型號 Model	型式 Description	建議使用數量 Recom. number of use
<b>ASC4-M5</b>	90度設計 Ø4管徑 90 degrees design ø4 diameter	2
<b>ASC6-M5</b>	90度設計 Ø6管徑 90 degrees design ø6 diameter	2
<b>AAC4-M5</b>	直通設計 Ø4管徑 Straight design ø4 diameter	2
<b>AAC6-M5</b>	直通設計 Ø6管徑 Straight design ø6 diameter	2

## RSWS 快速換爪系統 Quick change finger system

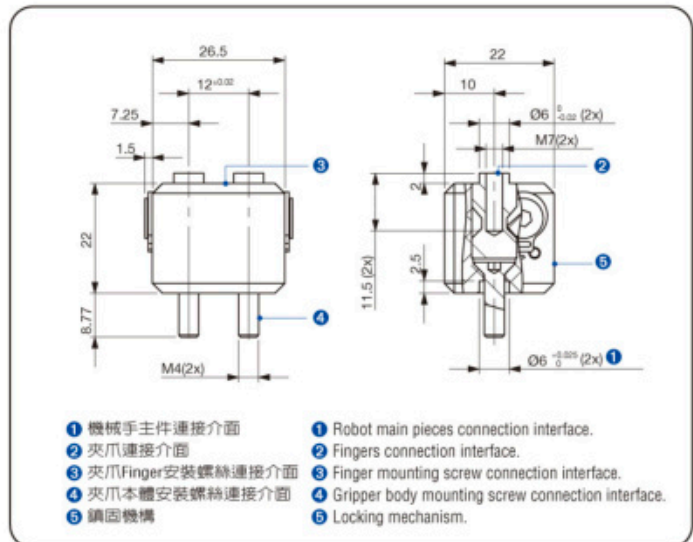

- 1 機械手主件連接介面      1 Robot main pieces connection interface.
- 2 夾爪連接介面              2 Fingers connection interface.
- 3 夾爪/Finger安裝螺絲連接介面      3 Finger mounting screw connection interface.
- 4 夾爪本體安裝螺絲連接介面      4 Gripper body mounting screw connection interface.
- 5 鎖回機構                      5 Locking mechanism.

- RSWS快速換爪系統可允許在機械夾爪主件上手動快速更換上爪。夾爪皆需要兩個轉接器(RSWS-B)與一個快速更換底座(RSWS-A)。
- RSWS finger quick change system, fingers on the top of the gripper can quickly be changed manually.  
1 set of quick-change base (RSWS-A) and 2 sets of quick-change connector (RSWS-B) are needed for every gripper.

型號 Model	型式 Type	兩組夾爪建議使用數量 Recom. number of use for 2 grippers
<b>RSWS-A-66</b>	快速更換底座 Quick-change base	2
<b>RSWS-B-66</b>	快速更換連接器 Quick-change connector	4



### RGN-plus 80



#### 夾持力 Gripping force 夾持力與 夾爪 (finger) 長度對照表 Gripping force and jaw (finger) length chart

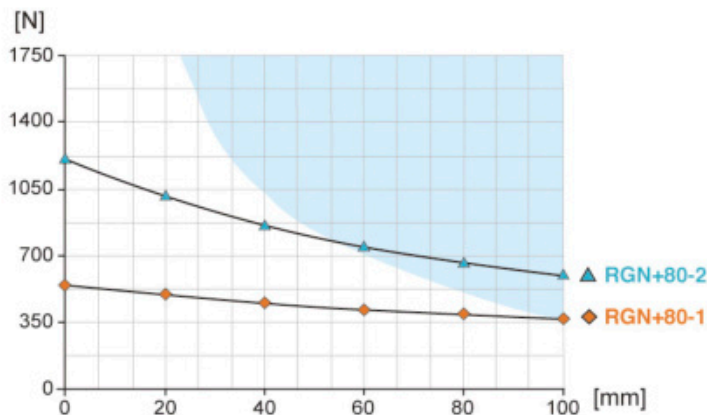

顏色區域：會增加夾爪磨損及撕裂機會  
Colored area: increased wear and tear to be expected

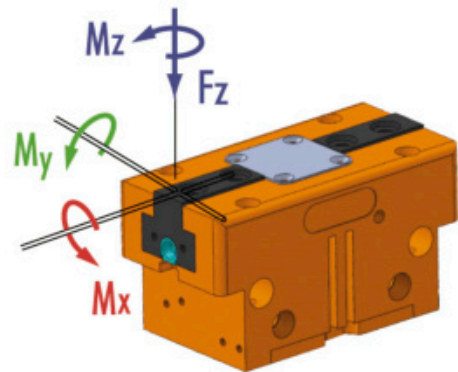

- Mx max. 80.0 Nm
- My max. 60.0 Nm
- Mz max. 50.0 Nm
- Fz max. 1800.0 N

#### 技術資料 Technical data

型號 Model		RGN+80-1	RGN+80-2
單爪行程 Stroke per jaw	mm	8	4
關閉力 Closing force	N	550	1230
開啓力 Opening force	N	590	1320
關閉/開啓時間 Closing/opening Time	s	0.04 / 0.04	0.04 / 0.04
重複精度 Repeatability	+/- mm	0.01	0.01
最小壓力 Min. pressure	bar	3	3
最大壓力 Max. pressure	bar	8	8
最小/最大溫度 Min. /max. temperature	°C	5 - 80	5 - 80
壓縮空氣消耗量 Compressed air consumption	cm <sup>3</sup>	23.6	23.6
重量 Weight	Kg	0.495	0.495
建議工件重量 Recom. work piece weight	Kg	2.6	6

# Classic 2-Jaw Parallel Gripper

## 外觀尺寸圖 Dimensions

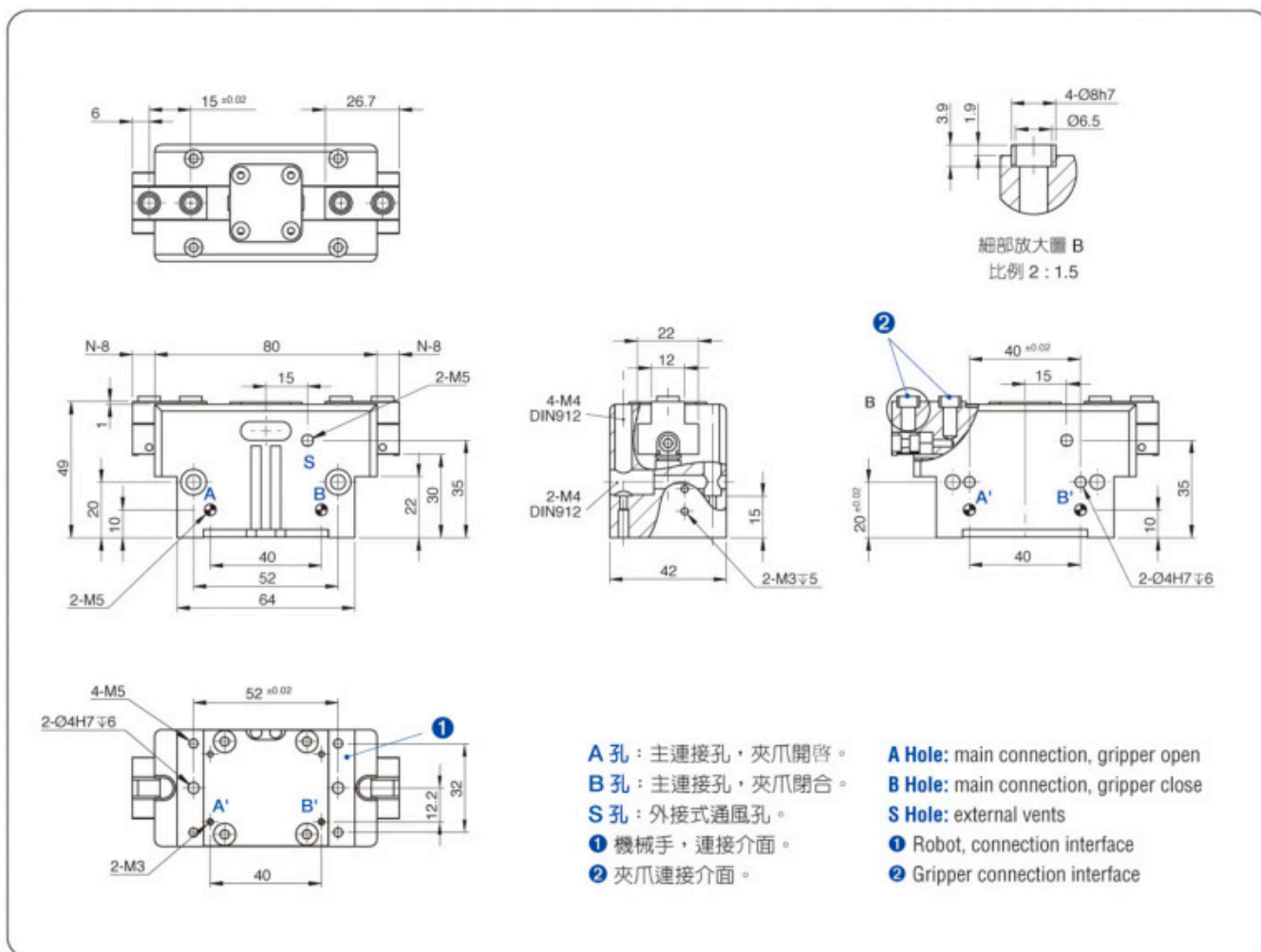

■ 上圖為閉爪時的基本款，不含選配物件尺寸。 ■ The picture shows the basic models when closing, excluding optional object size.

## 背板供氣示意圖 Hose-free direct connection

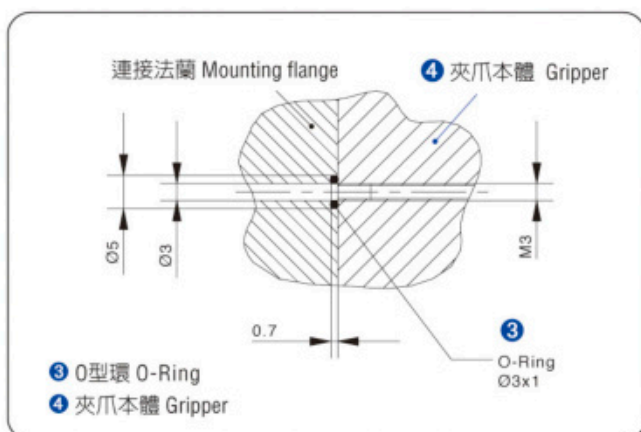

- 直接連結供氣口，壓縮空氣直接供給夾爪使用，無須外接管線，可將壓力介質饋入安裝板上的內孔。
- Direct link air supply port, compressed air supplied directly to the jaws, no external piping, pressure medium can be fed into the hole on the mounting plate

## 求心襯套尺寸圖 Centering sleeve

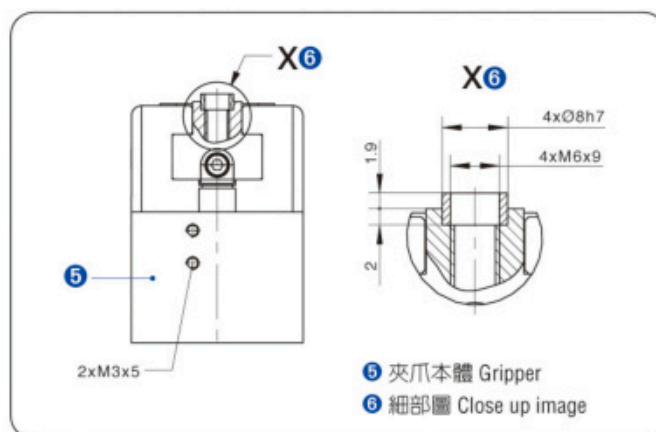

- 使用求心襯套來固定機械手指，達到準確定位。
- Using centering sleeve to fix the mechanical fingers, to achieve accurate positioning.

### (無接觸式)側邊感應器系統 (Non-contact) Side sensor system

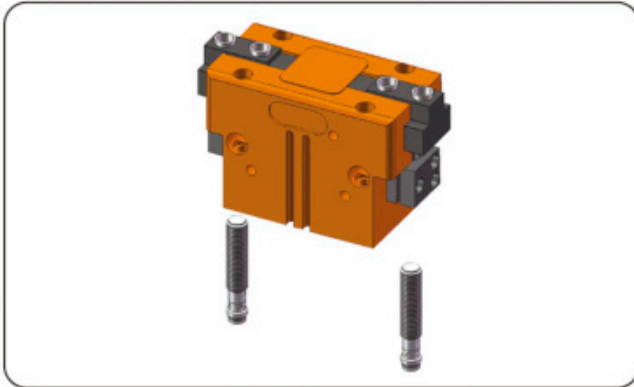

- (無接觸式)側邊終端位置監控:  
夾爪行程感應器，可直接由側邊安裝。
- 每個機械夾爪需要至少需要2個感應器(無接觸式)。
- (Non-contact) Side terminal position monitoring:  
Jaw stroke sensor can be installed directly from the sides.
- Each mechanical gripper needs at least two sensors (non-contact)

型號 Model	建議使用數量 Recom. number of use
IN80-M8	2

### (接觸式)C型槽感應器系統 (Contact) C-slot sensor system

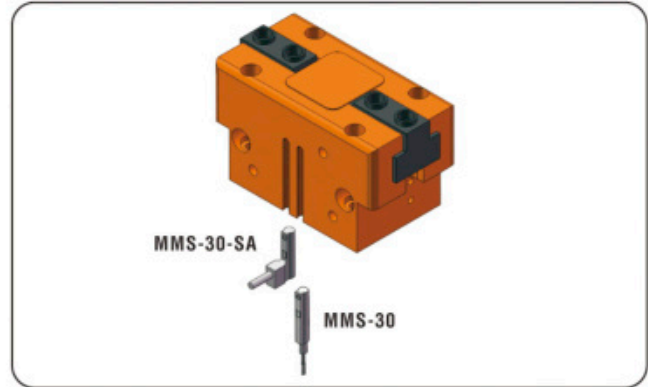

- 接觸式C型槽終端位置監控:  
夾爪磁簧感應器，安裝於夾爪C型槽內。
- 每個機械夾爪需要至少需要2個感應器(接觸式)。
- Contact C-slot terminal position monitoring:  
Gripper magnetic field sensor, installed in the C-slot.
- Each mechanical gripper needs at least two sensors (contact)

型號 Model	型式 Description	建議使用數量 Recom. number of use
MMS-30	直行設計(兩線無接點) Straight design (two-line non-contact)	2
MMS-30-SA	90度設計(兩線無接點) 90 degrees design (two-line non-contact)	2

### 夾爪素材 Universal jaw set

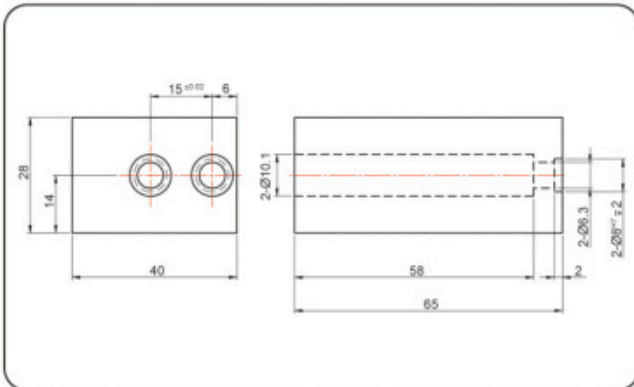

- 素材夾爪供客戶自行加工，螺絲連接介面也需自行加工。
- Jaw sets are provided for customer self-processing, screw connection interface also need their own processing.

型號 Model	材質 Description	建議使用數量 Recom. number of use
ABR-plus 80	鋁 Aluminium	2
SBR-plus 80	鐵 Iron	2

### 防塵罩模組 Dust protection module

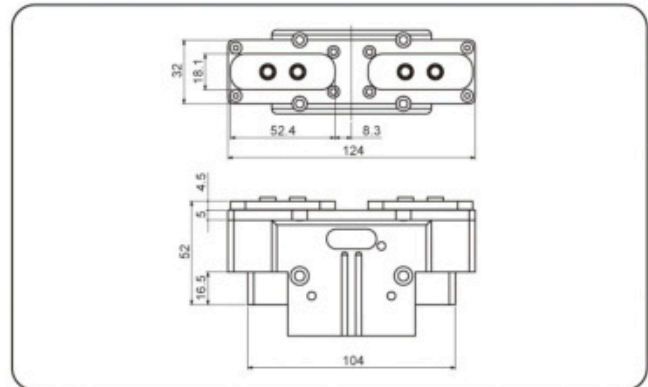

- 安裝螺絲連接介面，請見基本款。
- 防塵保護款增加了防止滲透性物質進入的等級  
夾爪長度需從防塵罩上的連接面量起。
- Mounting screw connection interface, see basic models.
- Dust protection is to upgrade the IP level and prevent from leaking materials into the gripper. The length of fingers need to be measured from the surface of dust cover.

型號 Model	材質 Description	建議使用數量 Recom. number of use
RGN+80-1-SD	鋁 Aluminium	1

## 夾爪最大可允許偏心率 Max permissible centrifugal degree

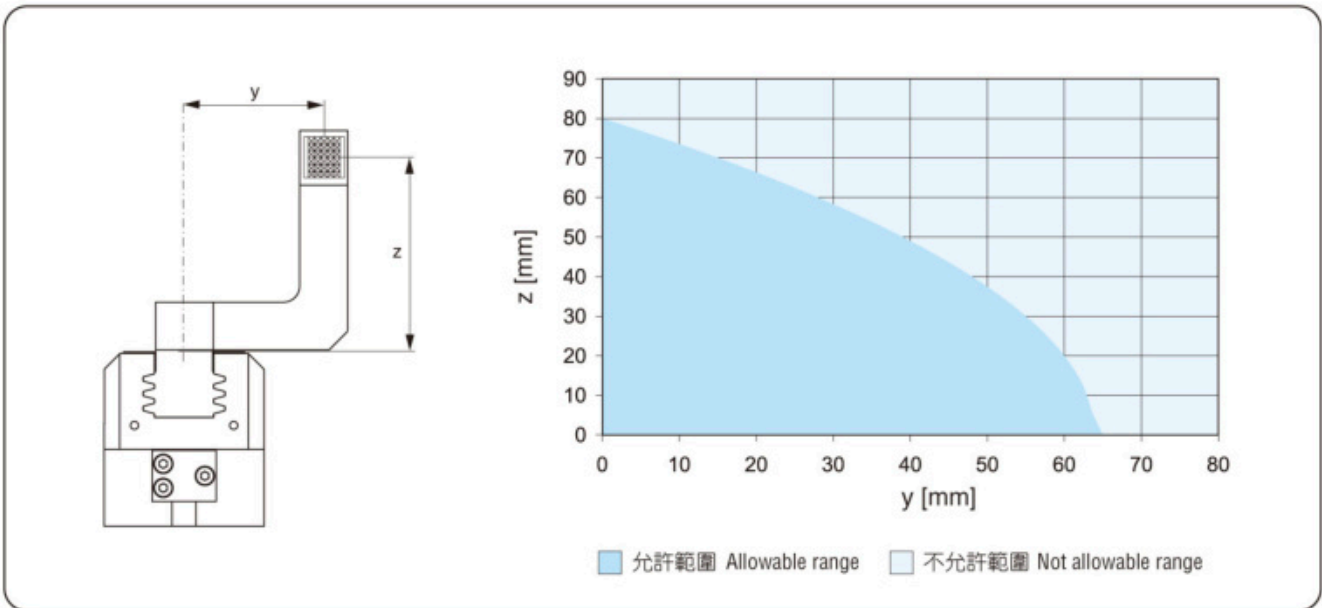

- 以上曲線圖適用於基本款(行程-1夾爪本體)。
- The graph above applies to basic models (stroke -1 jaws body)

## 夾爪調速閥 Speed control valve

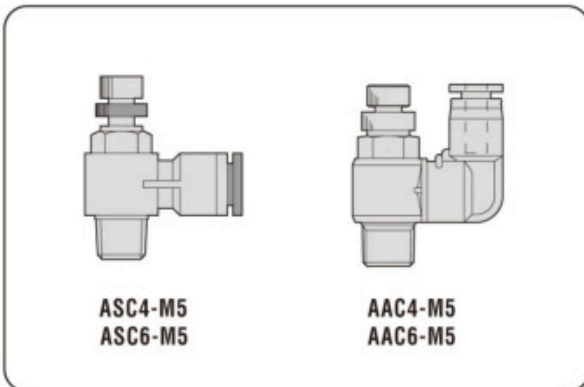

- 夾爪專用調速閥：  
調整夾爪開張速度專用調速閥門
- 每個機械夾爪需要至少2個調速閥。
- Speed control valve special for grippers:  
Special for adjusting the opening speed of gripper.
- Each mechanical gripper needs at least two speed control valves.

型號 Model	型式 Description	建議使用數量 Recom. number of use
<b>ASC4-M5</b>	90度設計 Ø4管徑 90 degrees design ø4 diameter	2
<b>ASC6-M5</b>	90度設計 Ø6管徑 90 degrees design ø6 diameter	2
<b>AAC4-M5</b>	直通設計 Ø4管徑 Straight design ø4 diameter	2
<b>AAC6-M5</b>	直通設計 Ø6管徑 Straight design ø6 diameter	2

## RSWS 快速換爪系統 Quick change finger system

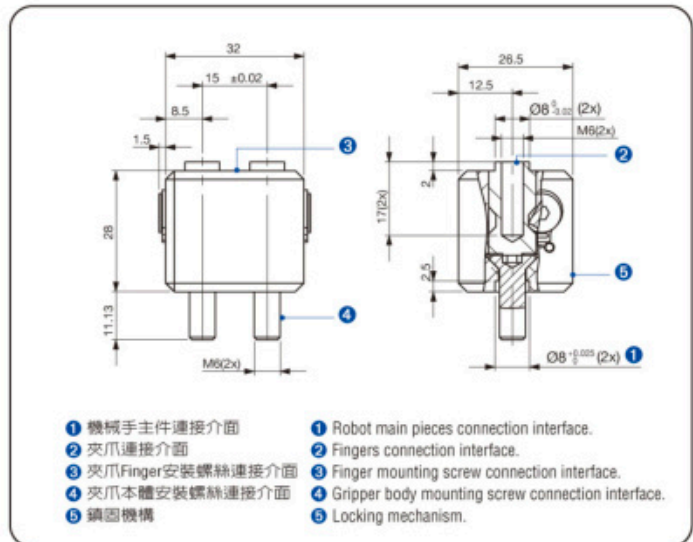

- RSWS快速換爪系統可允許在機械夾爪主件上手動快速更換上爪。夾爪皆需要兩個轉接器(RSWS-B)與一個快速更換底座(RSWS-A)。
- RSWS finger quick change system, fingers on the top of the gripper can quickly be changed manually.  
1 set of quick-change base (RSWS-A) and 2 sets of quick-change connector (RSWS-B) are needed for every gripper.

型號 Model	型式 Type	兩組夾爪建議使用數量 Recom. number of use for 2 grippers
<b>RSWS-A-80</b>	快速更換底座 Quick-change base	2
<b>RSWS-B-80</b>	快速更換連接器 Quick-change connector	4

### RGN-plus 100



**夾持力 Gripping force** 夾持力與 夾爪 (finger) 長度對照表 Gripping force and jaw (finger) length chart

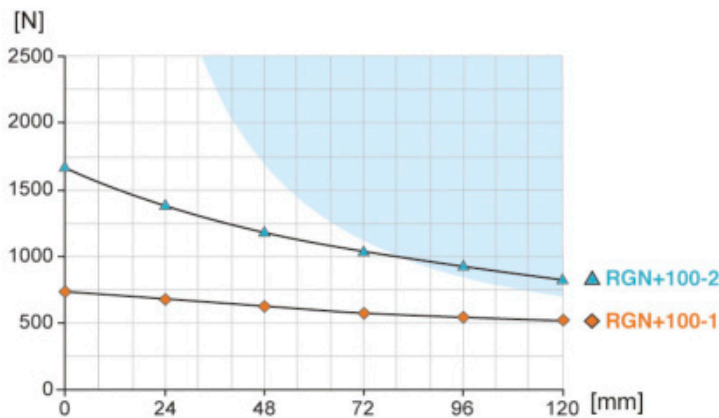

顏色區域：會增加夾爪磨損及撕裂機會  
Colored area: increased wear and tear to be expected

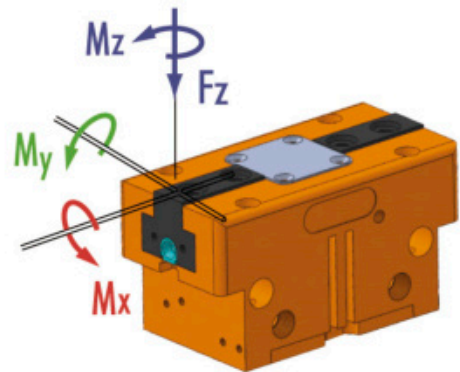

- Mx max. 100.0 Nm
- My max. 90.0 Nm
- Mz max. 75.0 Nm
- Fz max. 2500.0 N

### 技術資料 Technical data

型號 Model		RGN+100-1	RGN+100-2
單爪行程 Stroke per jaw	mm	10	5
關閉力 Closing force	N	740	1650
開啓力 Opening force	N	795	1770
關閉/開啓時間 Closing/opening Time	s	0.07 / 0.07	0.07 / 0.07
重複精度 Repeatability	+/- mm	0.01	0.01
最小壓力 Min. pressure	bar	3	3
最大壓力 Max. pressure	bar	8	8
最小/最大溫度 Min. /max. temperature	°C	5 - 80	5 - 80
壓縮空氣消耗量 Compressed air consumption	cm <sup>3</sup>	39.3	39.3
重量 Weight	Kg	0.85	0.85
建議工件重量 Recom. work piece weight	Kg	3.6	8.1

# Classic 2-Jaw Parallel Gripper

## 外觀尺寸圖 Dimensions

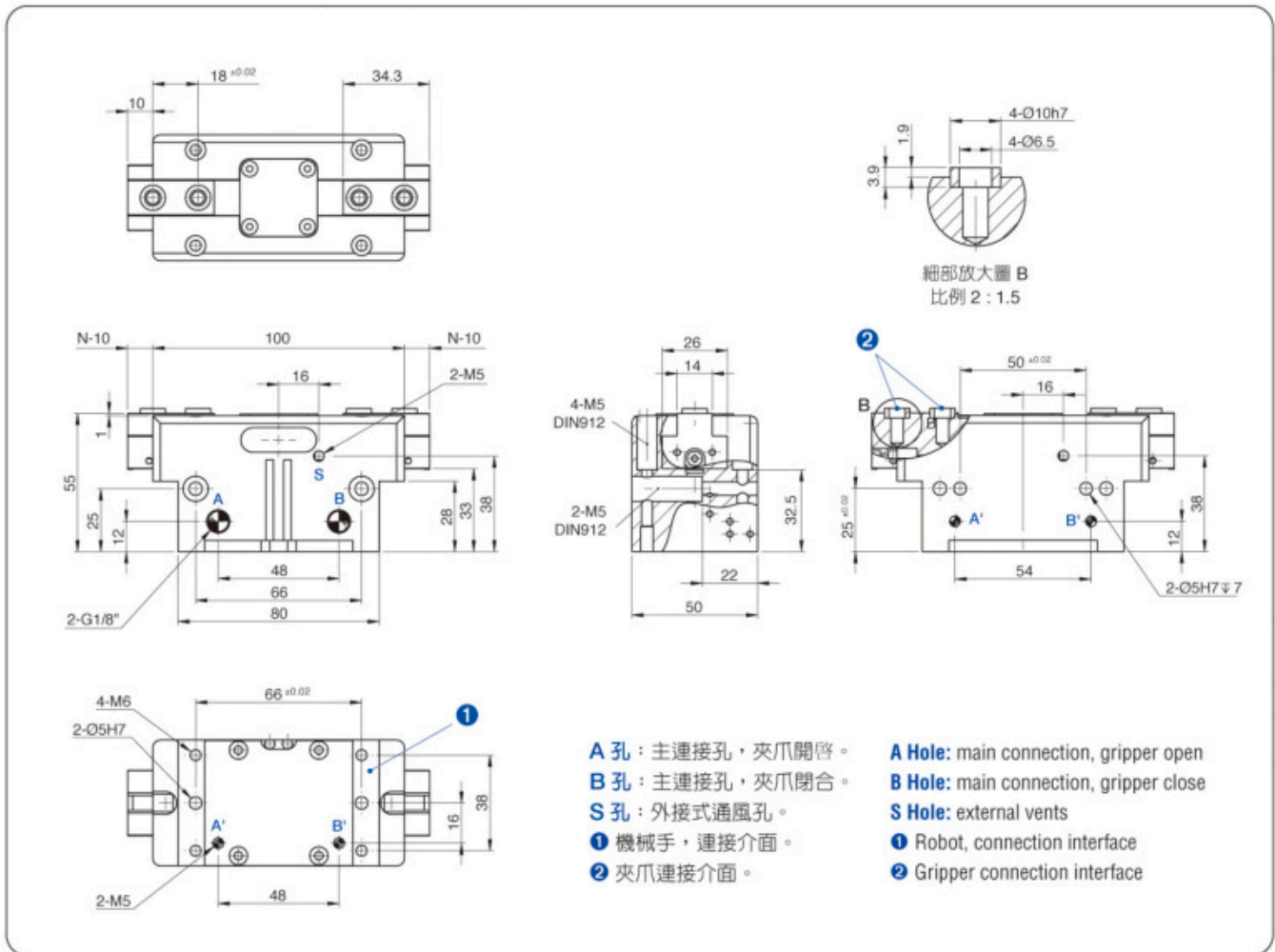

RGN-plus 100

■ 上圖為閉爪時的基本款，不含選配物件尺寸。 ■ The picture shows the basic models when closing, excluding optional object size.

## 背板供氣示意圖 Hose-free direct connection

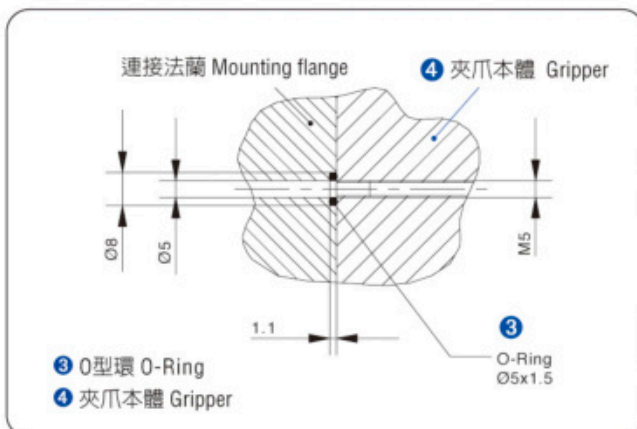

- 直接連結供氣口，壓縮空氣直接供給夾爪使用，無須外接管線，可將壓力介質饋入安裝板上的內孔。
- Direct link air supply port, compressed air supplied directly to the jaws, no external piping, pressure medium can be fed into the hole on the mounting plate

## 求心襯套尺寸圖 Centering sleeve

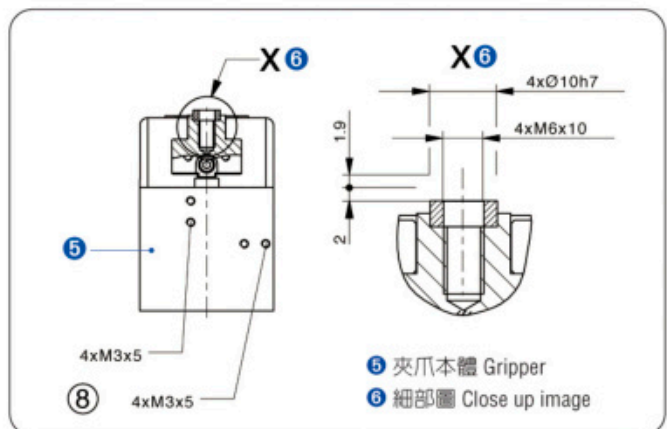

- 使用求心襯套來固定機械手指，達到準確定位。
- Using centering sleeve to fix the mechanical fingers, to achieve accurate positioning.

### (無接觸式)側邊感應器系統 (Non-contact) Side sensor system

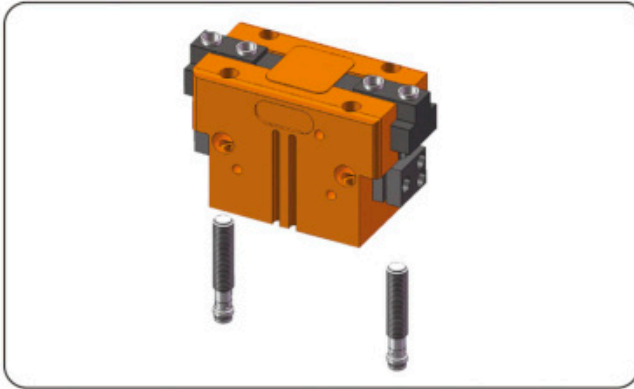

- (無接觸式)側邊終端位置監控:  
夾爪行程感應器，可直接由側邊安裝。
- 每個機械夾爪需要至少2個感應器(無接觸式)。
- (Non-contact) Side terminal position monitoring:  
Jaw stroke sensor can be installed directly from the sides.
- Each mechanical gripper needs at least two sensors (non-contact)

型號 Model	建議使用數量 Recom. number of use
IN80-M8	2

### (接觸式)C型槽感應器系統 (Contact) C-slot sensor system

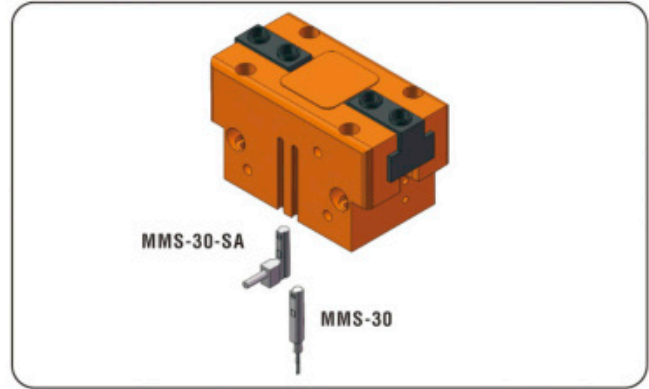

- 接觸式C型槽終端位置監控:  
夾爪磁簧感應器，安裝於夾爪C型槽內。
- 每個機械夾爪需要至少2個感應器(接觸式)。
- Contact C-slot terminal position monitoring:  
Gripper magnetic field sensor, installed in the C-slot.
- Each mechanical gripper needs at least two sensors (contact)

型號 Model	型式 Description	建議使用數量 Recom. number of use
MMS-30	直行設計(兩線無接點) Straight design (two-line non-contact)	2
MMS-30-SA	90度設計(兩線無接點) 90 degrees design (two-line non-contact)	2

### 夾爪素材 Universal jaw set

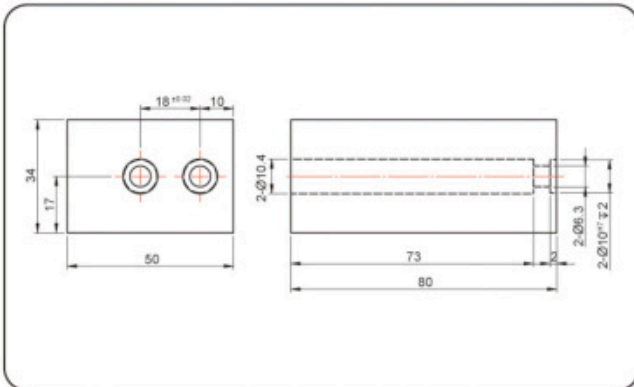

- 素材夾爪供客戶自行加工，螺絲連接介面也需自行加工。
- Jaw sets are provided for customer self-processing, screw connection interface also need their own processing.

型號 Model	材質 Description	建議使用數量 Recom. number of use
ABR-plus 100	鋁 Aluminium	2
SBR-plus 100	鐵 Iron	2

### 防塵罩模組 Dust protection module

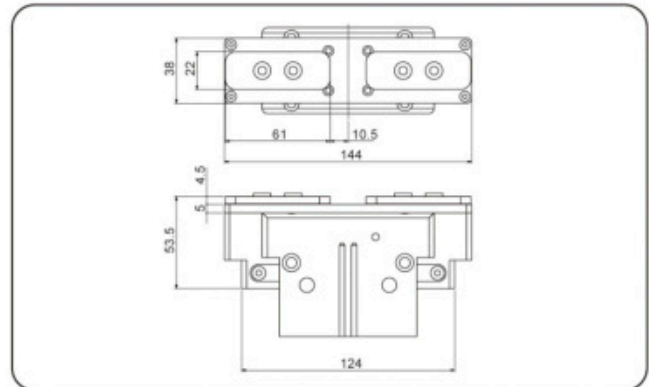

- 安裝螺絲連接介面，請見基本款。
- 防塵保護款增加了防止滲透性物質進入的等級  
夾爪長度需從防塵罩上的連接面量起。
- Mounting screw connection interface, see basic models.
- Dust protection is to upgrade the IP level and prevent from leaking materials into the gripper. The length of fingers need to be measured from the surface of dust cover.

型號 Model	材質 Description	建議使用數量 Recom. number of use
RGN+100-1-SD	鋁 Aluminium	1

## 夾爪最大可允許偏心率 Max permissible centrifugal degree

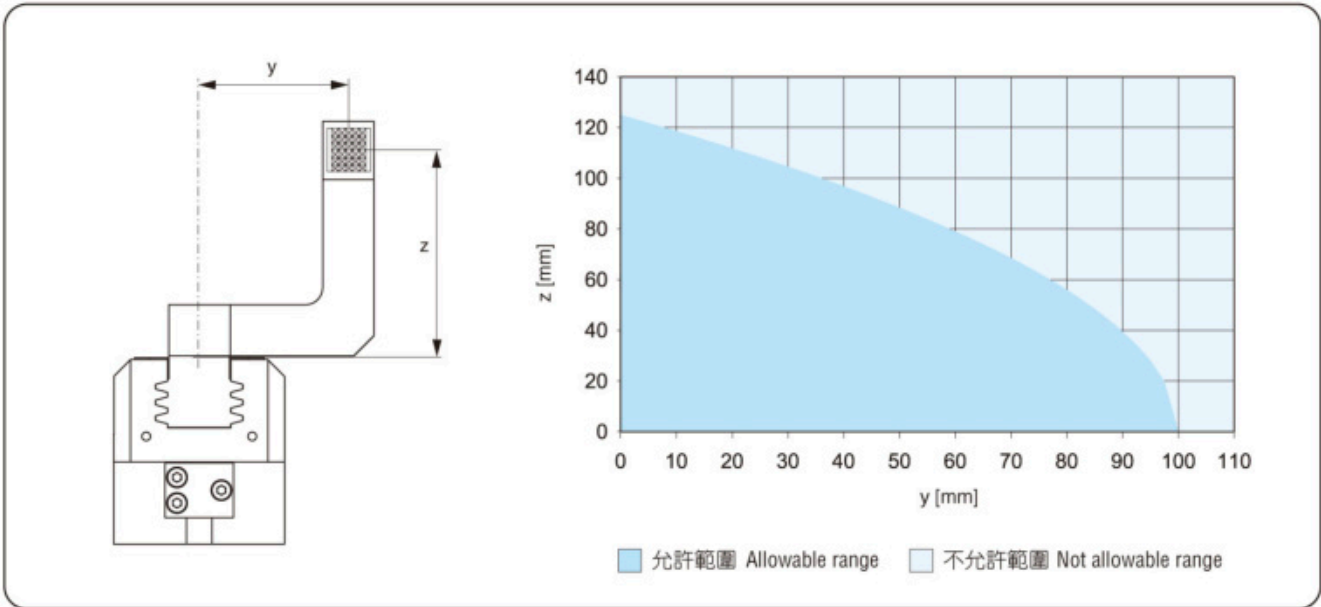

- 以上曲線圖適用於基本款(行程-1夾爪本體)。
- The graph above applies to basic models (stroke -1 jaws body)

## 夾爪調速閥 Speed control valve

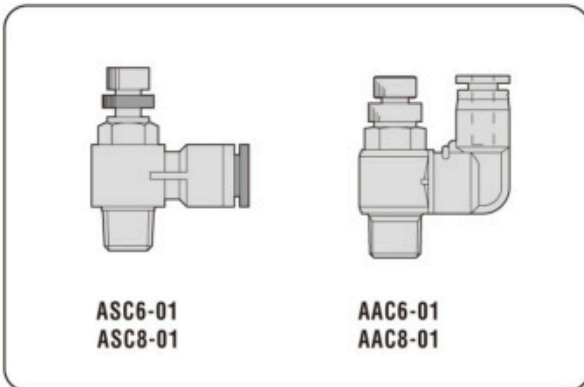

- 夾爪專用調速閥：  
調整夾爪開張速度專用調速閥門
- 每個機械夾爪需要至少2個調速閥。
- Speed control valve special for grippers:  
Special for adjusting the opening speed of gripper.
- Each mechanical gripper needs at least two speed control valves.

型號 Model	型式 Description	建議使用數量 Recom. number of use
ASC6-01	90度設計 Ø6管徑 90 degrees design ø6 diameter	2
ASC8-01	90度設計 Ø8管徑 90 degrees design ø8 diameter	2
AAC6-01	直通設計 Ø6管徑 Straight design ø6 diameter	2
AAC8-01	直通設計 Ø8管徑 Straight design ø8 diameter	2

## RSWS 快速換爪系統 Quick change finger system

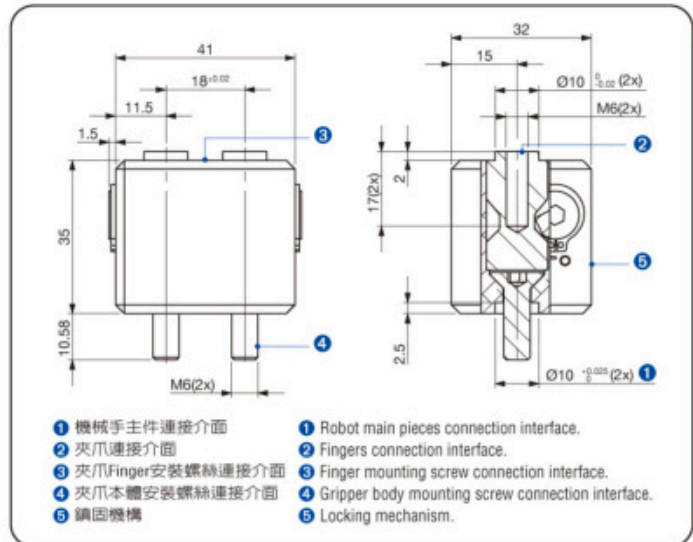

- RSWS快速換爪系統可允許在機械夾爪主件上手動快速更換上爪。夾爪皆需要兩個轉接器(RSWS-B)與一個快速更換底座(RSWS-A)。
- RSWS finger quick change system, fingers on the top of the gripper can quickly be changed manually.  
1 set of quick-change base (RSWS-A) and 2 sets of quick-change connector (RSWS-B) are needed for every gripper.

型號 Model	型式 Type	兩組夾爪建議使用數量 Recom. number of use for 2 grippers
RSWS-A-100	快速更換底座 Quick-change base	2
RSWS-B-100	快速更換連接器 Quick-change connector	4