

DROP HINGE (ADJUSTABLE TYPE) GS-SDH-001



- 3-way adjustment. Overlay: 14~16mm / Door gap: +1mm / Horizontal: ± 1 mm
- Can be used with SOFT-DOWN STAY GS-SDS-100 and GS-NSDX-10
- Bore depth: 12mm
- Pan head tapping screw 3 x 13 in black (sold separately) for GS-SDH-001BL is also available. Sold in bags (300 pcs per pack).
- Glass door type is also available.

[Remarks]

- Use with a stay for downward-opening.

[Recommended Screws]

- Pan head tapping screw 3x 13

● Outline drawing

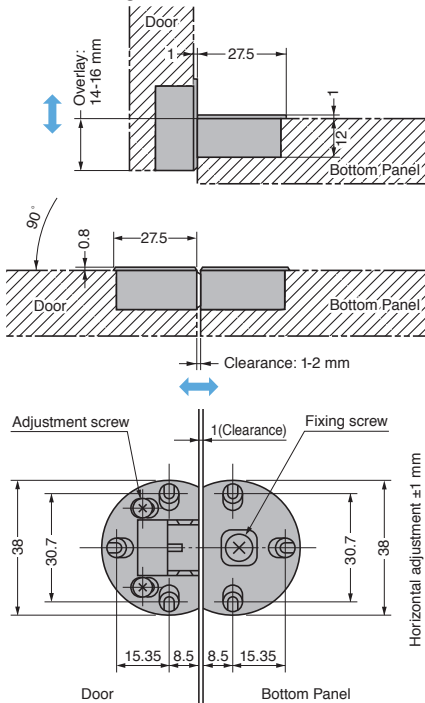

● Locus chart (How to Use the Locus Chart)

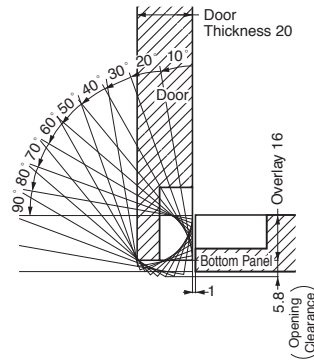

A gap equivalent to opening clearance is required for door opening and closing. Drawing above is door thickness 20 mm, bottom panel thickness 20 mm and 16 mm overlay. The value of opening clearance may change with the door thickness. Please confirm in the locus chart.

[Cut Out Dimensions]

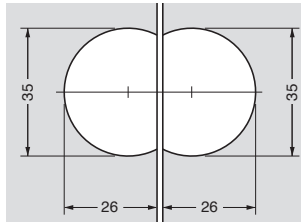

[Number of Hinges]

In case of door thickness up to 20 mm. Material: particle board.

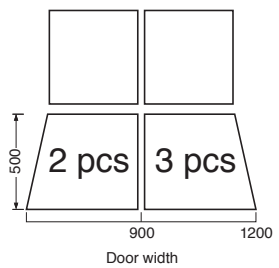

[Application Example]



Combination with HEAVY DUTY SOFT-DOWN STAY GS-HDS-10

[Hinge]

Item Name	Material	Finish	Overlay	Recommended Door Thickness	Opening Angle	Weight (g)
GS-SDH-001	Zinc Alloy	Nickel	14~16	16~20	90°	85
GS-SDH-001BL	(ZDC)	Black Enamel Finish				85