

BUTT HINGE HG-P100



- PVC material, with excellent chemical resistance.
- No metal powder generated because all parts (except shaft) are made of resin.
- Clear type does not affect appearance even on transparent door.
- Lead-free.

[Applications]

- Semiconductor manufacturing equipment, liquid crystal manufacturing equipment, etc.

[Remarks]

- Screw may become loose, depending on use situation. Please check appropriately.
- Use washers when fixing with screws.
- When installing to aluminium frame, over-tightening may damage mounting screws.
- Load capacity is the value when using two hinges. For calculation conditions, please refer to INDEX

[Recommended Screws]

- M5 screw (Recommended tightening torque 2.0N · m)

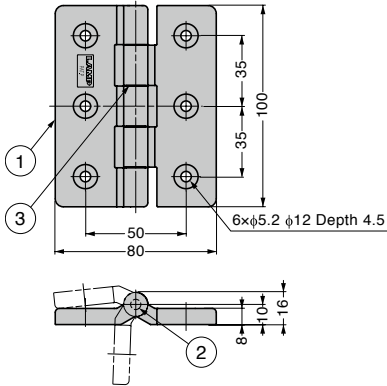

No.	Part Name	Material	Finish / Colour
①	Leaf	PVC	Clear
②	Shaft	Titanium Alloy	Plain
③	Washer	PEEK	-

Reference door weight: 8kg
(In case of door size W600x H800, using 2 pcs vertically)

Item Name	Load Capacity N/2 pcs	Load Capacity kgf/2 pcs	Weight (g)
GS-HG-P100	98	10	74