

LID STAY GS-S-24, GS-S-27, GS-S-25

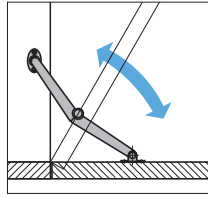

[Installation] Right-handed



Opening Direction	Description
<p>Downward-opening</p>	-

[Remarks]

● When installing this stay to sheet metal, be sure to perform thread relief processing (chamfering) on the mounting surface side (cabinet side). In this way, screw head will not protrude when the stay is fixed.

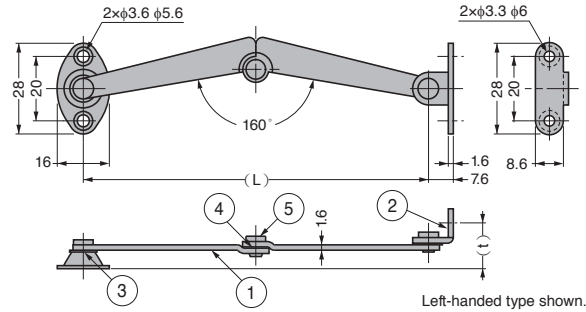

No.	Part Name	Material	Finish
①	Body	Steel (SPCC)	Chrome
②	Bracket		
③	Washer	PA	Natural
④	Washer	Brass	Tin Cobalt Plating
⑤	Shaft		

Item Name	Type	L	t	Tension Force N/pc	Tension Force kgf/pc	Weight (g)
GS-S-24R	Right-handed	105.5	13.6	326	33.3	21
GS-S-24L	Left-handed					
GS-S-27R	Right-handed	133	13.4	325	33.2	31
GS-S-27L	Left-handed					
GS-S-25R	Right-handed	163	13.6	287	29.3	35
GS-S-25L	Left-handed		13.4			