

# STAINLESS STEEL MINI SLIDE (2-WAY) GS-SCRW2-15S

**LOAD CAPACITY** 137~177 N/pair

**L=R**

**2-WAYS**

**SUS**



- 3/4 extension (2 members).
- Only 15.5mm in height with small deflection, suitable for various places.
- Grease (NSF H1 Registered Food Grade Lubricants) for food machinery is used.

**[Remarks]**

- Types with slide length 80mm have no holes marked with ※.
- Install stopper separately to protect rails and retainers from strong shock.

**[Recommended Screws]**

- M2.6 low head screw (for outer member)
- M2.6 screw (for inner member) Screw length = Panel thickness + Max. 1.5 mm

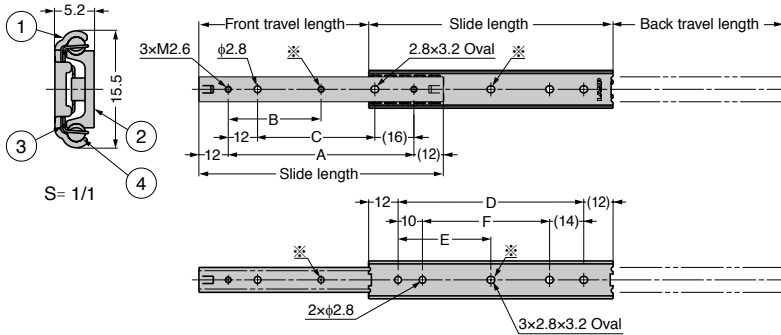

No.	Part Name	Material
①	Outer Member	Stainless Steel (SUS304)
②	Inner Member	
③	Retainer	Stainless Steel (SUS440)
④	Balls	

Sold by piece.

Item Name	Slide Length	Travel Length		A	B	C	D	E	F	Vertical Installation		Weight (g/pc)
		Front	Back							Load Capacity N/pair	Load Capacity kgf/pair	
GS-SCRW2-15S-80A	80	48.5	48.5	56	-	28	56	-	32	137	14	21
GS-SCRW2-15S-100A	100	68.5	68.5	76	38	48	76	38	52	157	16	26
GS-SCRW2-15S-150A	150	94.5	94.5	126	63	98	126	63	102	177	18	41