

CLAMP GS-MR-CLP For Mini Guide Rail GS-MRS



[Application Image]



- Temporary fixing and positioning clamp for mini guide rail GS-MRS
- Push the side of rail to simply fix.
- Install to mini guide block GS-MR with screws.

[Remarks]

- Do not use under moment load.
- Fixing position may shift when an external force more than the retaining force (reference value) is applied.
- Knob tip may be damaged when the knob tightening torque is exceeded.
- Mounting screws not included.

[Application Example]

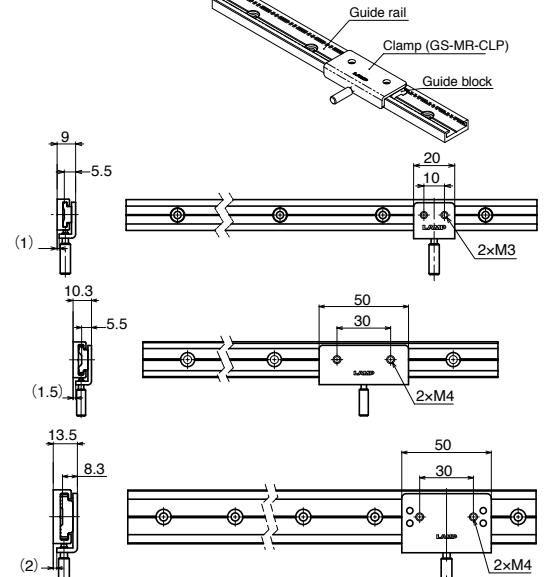

※Only GS-MR-30CLP is half-punched for positioning.

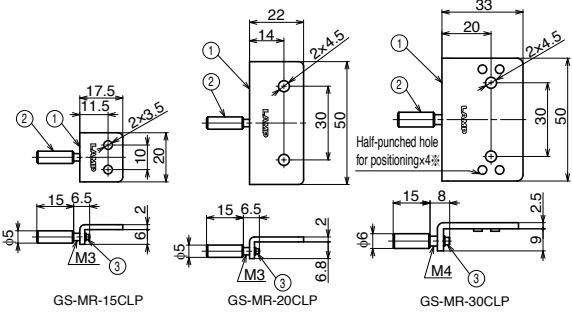

No.	Product Name	Material	Finish / Colour
①	Plate	Stainless Steel (SUS304)	Barrel Polished
②	Knob Body	Stainless Steel (SUS303)	Plain
③	Knob Tip	POM	Black

Item Name	Retaining N (Reference)	Knob Tightening Torque N·m	Weight (g)	Guide Block
GS-MR-15CLP	Max. 7	Max. 0.05	8.6	GS-MR-15CS
GS-MR-20CLP	Max. 7	Max. 0.05	22.6	GS-MR-20CS
GS-MR-30CLP	Max. 14	Max. 0.1	40.8	GS-MR-30CS