

PLN DESIGN CASTER

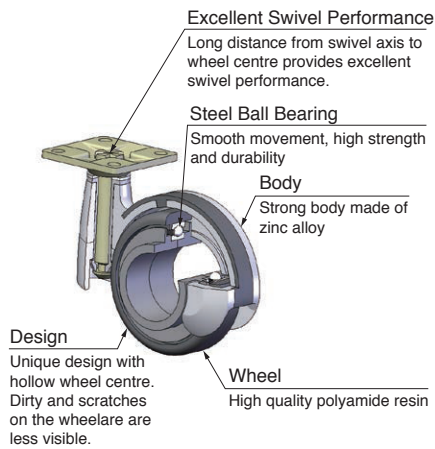

- Improved PL caster provides higher load capacity and operability.
- Excellent design
Unique design with hollow wheel centre. Combination of smooth curve and black or chrome plating.
- Improved load capacity and operability
Steel ball bearing improves load capacity and rotation smoothness.
- Wide range of applications
Medical equipment, audio products, beauty equipment, wagons, chairs, travel bags, and displays, etc.

DESIGN CASTER **GS-PLN50N** Threaded Bolt Type

LOAD CAPACITY 785 N

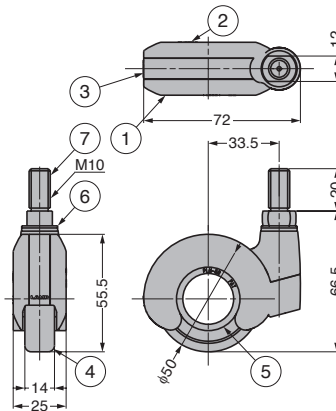

[Remarks]

- Do not use it on a nonsmooth surface. Deformation, damage or wheel detachment may occur.
- The load capacities in the table below are static load values.

No.	Part Name	Material	Finish/Colour
①	Body (Right)	Zinc Alloy (ZDC)	As below.
②	Body (Left)		
③	Cover	POM	Dark Grey
④	Wheel	PA	Black
⑤	Inner Ring		Dark Grey
⑥	Mounting Plate	Stainless Steel (SUS304)	Barrel Polished
⑦	Threaded Bolt	Steel (SWCH)	Coloured Zinc Chromate

Item Name	Finish/Colour (Body)	Load Capacity N/pc	Load Capacity kgf/pc	Weight (g)
GS-PLN50N10BL	Paint/Black	785	80	203
GS-PLN50N10CR	Chrome			