

TWIN WHEEL CASTER GS-GX60N12 Threaded Bolt Type

LOAD CAPACITY 1470 N

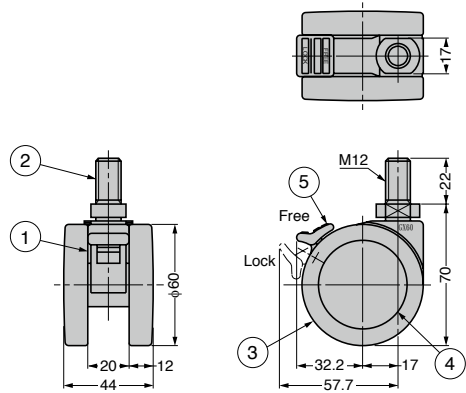

● Stable twin wheel structure provides smooth movement and excellent durability.



Drawing above shows the model with brake.

No.	Part Name	Material	Finish/Colour
①	Body	Aluminium Alloy (ADC)	Barrel Polished
②	Threaded Bolt	Steel (SWCH)	Coloured Zinc Chromate (Trivalent)
③	Wheel	PA	Black
④	Cover		
⑤	Lever		

Item Name	Type	Load Capacity N/pc	Load Capacity kg/pc	Weight (g)
GS-GX60N12S	With Brake	1470	150	185
GS-GX60N12	Without Brake			180