

TWIN WHEEL CASTER **GS-GX60P** Plate Type

LOAD CAPACITY 1470 N

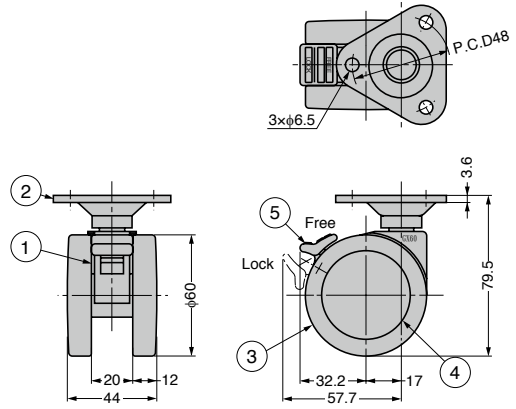

- Stable twin wheel structure provides smooth movement and excellent durability.



Drawing above shows the model with brake.

No.	Part Name	Material	Finish/Colour
①	Body	Aluminium Alloy (ADC)	Barrel Polished
②	Plate	Steel (SPHC)	Coloured Zinc Chromate (Trivalent)
③	Wheel	PA	Black
④	Cover		
⑤	Lever		

Item Name	Type	Load Capacity N/pc	Load Capacity kgf/pc	Weight (g)
GS-GX60PS	With Brake	1470	150	225
GS-GX60P	Without Brake			