

TWIN WHEEL CASTER **GS-GX50P** Plate Type

LOAD CAPACITY 980 N

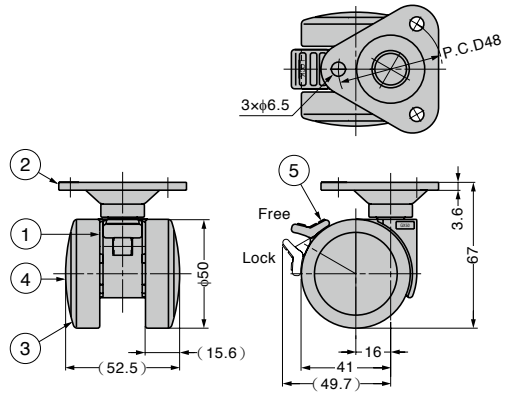

● Stable twin wheel structure provides smooth movement and excellent durability.



Drawing above shows the model with brake.

No.	Part Name	Material	Finish/Colour
①	Body	Aluminium Alloy	Barrel Polished
②	Plate	Steel	Coloured Zinc Chromate
③	Wheel	PA	Black
④	Cover		
⑤	Lever		

Item Name	Type	Load Capacity N/pc	Load Capacity kgf/pc	Weight (g)
GS-GX50PS	With Brake	980	100	235
GS-GX50P	Without Brake			230