

TWIN WHEEL CASTER **GS-T, GS-TSD** Threaded Bolt Type

LOAD CAPACITY 784~980 N

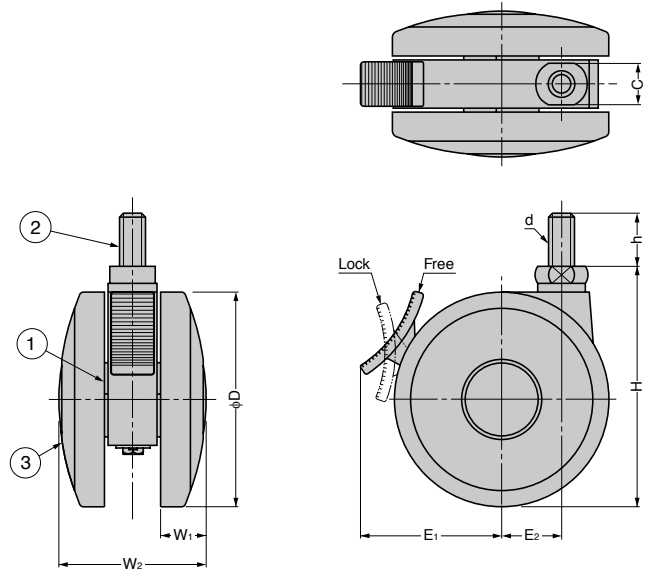

- Easy operation to lock on both wheel and swivel in one step.
- Wheels are coated in polyurethane which absorbs vibration and gives an extra smooth and quiet movement.



GS-TSD-100B shown.

No.	Part Name	Material	Finish/Colour
①	Body	PA	Light Grey
②	Threaded Bolt	Steel	Clear Zinc Chromate (Trivalent)
③	Wheel	PA + PUR	Light Grey

Item Name	Type	D	W ₁	W ₂	H	h	E ₁	E ₂	C	d	Load Capacity N/pc	Load Capacity kgf/pc	Weight (g)
GS-TSD-75B	With Brake	76	19	61	86	20	45	21	17	M10	784	80	260
GS-T-75B	Without Brake												240
GS-TSD-100B	With Brake	100	20	69	117.5	25	64	28	21	M12x 1.25	980	100	565
GS-T-100B	Without Brake												555