

TWIN WHEEL CASTER **GS-DB, GS-DS** Threaded Bolt Type

LOAD CAPACITY 490~784 N

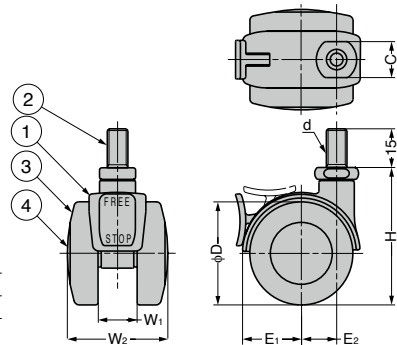
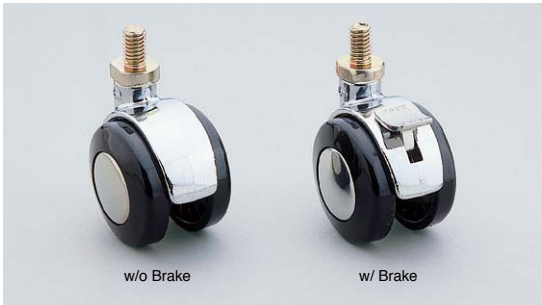

Drawing above shows the model with brake.

No.	Part Name	Material	Finish/Colour
①	Body	Zinc Alloy (ZDC)	Chrome
②	Threaded Bolt	Steel	Metric Screw Thread: Clear Zinc Chromate Inch Screw Thread: Coloured Zinc Chromate
③	Wheel	PA	Black
④	Cover	Stainless Steel (SUS430)	-

Item Name	Type	D	W ₁	W ₂	H	C	d	E ₁	E ₂	Load Capacity N/pc	Load Capacity kg/pc	Weight (g)
GS-DB-40-3	With Brake	40.5	15	39.5	53.5	14	W3/8	27	12.5	490	50	120
GS-DS-40-3	Without Brake						23.5	107				
GS-DB-40-8	With Brake						M8	27				120
GS-DS-40-8	Without Brake						23.5	107				
GS-DB-40-10	With Brake						M10	27				120
GS-DS-40-10	Without Brake						23.5	107				
GS-DB-50-3	With Brake	50.5	18	46	67.5	17	W3/8	33.5	17	784	80	204
GS-DS-50-3	Without Brake						29	190				
GS-DB-50-8	With Brake						M8	33.5				204
GS-DS-50-8	Without Brake						29	190				
GS-DB-50-10	With Brake						M10	33.5				204
GS-DS-50-10	Without Brake						29	190				