

TWIN WHEEL CASTER **GS-FA45N** Threaded Bolt Type

LOAD CAPACITY 490 N



- With red indicator to show locked state.

[Remarks]

- Push the stopper to handle. Red lock indicator means locked state.
- The load capacities in the table below indicate the loads when moving on a smooth surface.

| No. | Part Name | Material | Finish/Colour |
|-----|---------------|-----------------------|------------------------|
| ① | Body | Aluminium Alloy (ADC) | Silver Enamel Finish |
| ② | Threaded Bolt | Steel (SWCH) | Coloured Zinc Chromate |
| ③ | Wheel | PA | Black |
| ④ | Cover | | Black |
| ⑤ | Stopper | | Black, Red |

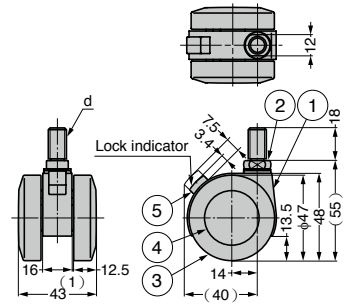

Drawing above shows the model with brake.

| Item Name | Type | d | Load Capacity N/pc | Load Capacity kgf/pc | Weight (g) |
|--------------|---------------|------|--------------------|----------------------|------------|
| GS-FA45N3SR | With Brake | W3/8 | 490 | 50 | 100 |
| GS-FA45N3R | Without Brake | | | | 97 |
| GS-FA45N10SR | With Brake | M10 | | | 100 |
| GS-FA45N10R | Without Brake | | | | 97 |