

TWIN WHEEL CASTER **GS-FP45N** Threaded Bolt Type

LOAD CAPACITY 392 N



- With red indicator to show locked state.

[Remarks]

- Push the stopper to handle. Red lock indicator means locked state.
- The load capacities in the table below indicate the loads when moving on a smooth surface.

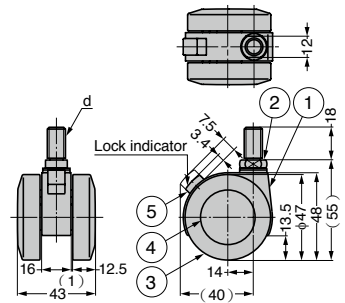

Drawing above shows the model with brake.

Item Name	Type	d	Load Capacity N/pc	Load Capacity kg/pc	Weight (g)
GS-FP45N3SR	With Brake	W3/8	392	40	84
GS-FP45N3R	Without Brake				79
GS-FP45N10SR	With Brake	M10	392	40	84
GS-FP45N10R	Without Brake				79

No.	Part Name	Material	Finish/Colour
①	Body	PA	Black
②	Threaded Bolt	Steel (SWCH)	Coloured Zinc Chromate
③	Wheel	PA	Black
④	Cover		Black, Red
⑤	Stopper		