

TWIN WHEEL CASTER GS-NB, GS-NS Threaded Bolt Type

LOAD CAPACITY 392-588 N

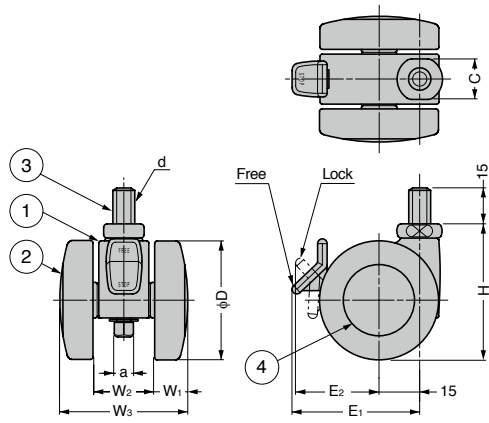

Drawing above shows the model with brake.

No.	Part Name	Material	Finish/Colour
①	Body	PA	Black
②	Wheel		
③	Threaded Bolt	Steel	Metric Screw Thread: Clear Zinc Chromate Inch Screw Thread: Coloured Zinc Chromate
④	Cover	Stainless Steel (SUS430)	Plain

Item Name	Type	D	H	E ₁	E ₂	W ₁	W ₂	W ₃	C	d	a	Load Capacity N/pc	Load Capacity kg/pc	Weight (g)
GS-NB-40-3	With Brake	40	45	48	32	12	21	45	14	W3/8	7	392	40	76
GS-NS-40-3	Without Brake			-	-					73				
GS-NB-40-8	With Brake			48	32					73				
GS-NS-40-8	Without Brake			-	-					70				
GS-NB-40-10	With Brake			48	32					76				
GS-NS-40-10	Without Brake			-	-					76				
GS-NB-50-3	With Brake	50	58	52	36	14	25	53	17	W3/8	8	588	60	128
GS-NS-50-3	Without Brake			-	-					117				
GS-NB-50-8	With Brake			52	36					121				
GS-NS-50-8	Without Brake			-	-					115				
GS-NB-50-10	With Brake			52	36					129				
GS-NS-50-10	Without Brake			-	-					119				