

# TWIN WHEEL CASTER GS-NB, GS-NS Plate Type

**LOAD CAPACITY 392~588 N**

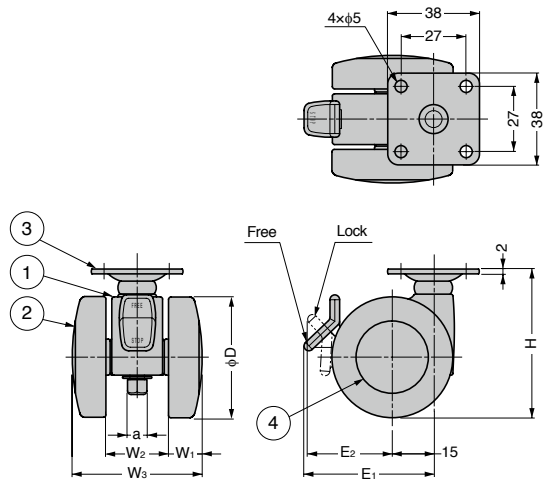

Drawing above shows the model with brake.

No.	Part Name	Material	Finish/Colour
①	Body	PA	Black
②	Wheel		
③	Plate	Steel	Clear Zinc Chromate
④	Cover	Stainless Steel (SUS430)	Plain

Item Name	Type	D	H	E <sub>1</sub>	E <sub>2</sub>	W <sub>1</sub>	W <sub>2</sub>	W <sub>3</sub>	a	Load Capacity N/pc	Load Capacity kg/pc	Weight (g)
GS-NB-40P	With Brake	40	49	48	32	12	21	45.5	7	392	40	89
GS-NS-40P	Without Brake			-	-							88
GS-NB-50P	With Brake	50	61	52	36	14	25	53	8	588	60	132
GS-NS-50P	Without Brake			-	-							128