

TWIN WHEEL CASTER **GS-BR** Plate Type

LOAD CAPACITY 294~392 N

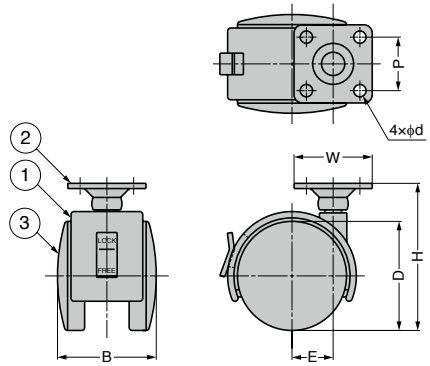

Drawing above shows the model with brake.

No.	Part Name	Material	Finish/Colour
①	Body	PA	Black
②	Plate	Steel (SPHC)	Clear Zinc Chromate (Trivalent)
③	Wheel	PA	Black

Item Name	Type	D	H	B	W	P	E	d	Load Capacity N/pc	Load Capacity kgf/pc	Weight (g)
GS-BR-20PS	With brake	45	61.5	42	38	26	16	6	294	30	104
GS-BR-20P	Without brake										95
GS-BR-25PS	With brake	53	71.5	48					392	40	149
GS-BR-25P	Without brake										138