

# TWIN WHEEL CASTER **GS-BR** Insert Bolt Type

**LOAD CAPACITY** 294~392 N



**[Parts Included]**

- Socket

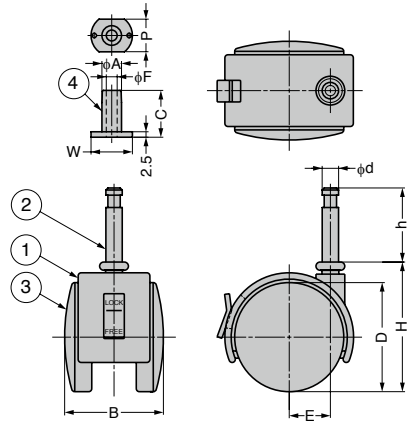

Drawing above shows the model with brake.

No.	Part Name	Material	Finish/Colour
①	Body	PA	Black
②	Insert Bolt	Steel	Clear Zinc Chromate (Trivalent)
③	Wheel	PA	Black
④	Socket	Polyethylene (PE)	-

Item Name	Type	D	H	h	B	E	d	A	W	C	F	P	Load Capacity N/pc	Load Capacity kgf/pc	Weight (g)
GS-BR-20SS	With Brake	45	53	36	42	16	8	11.5	22	30	7	17	294	30	85
GS-BR-20S	Without Brake														75
GS-BR-25SS	With Brake	53	63	36	48	20	8	11.5	22	30	7	17	392	40	124
GS-BR-25S	Without Brake														113