

SLIDING DOOR ROLLER GS-JC120 L Type w/o Bracket

Made to Order



- Non-bracket type of GS-JC115
- Bearing with rubber seal (dustproof seal type) provides excellent water resistance.
- Ideal for exterior application.
- 2 bearings are used for wheel, providing smooth movement even for heavy doors.

[Applications]

- Gates, etc.

[Remarks]

- Core rod for wheel diameter $\phi 90 \sim \phi 120$ is not grooved for E-ring.
- Core rod for $\phi 150 \sim \phi 200$ consists of one bolt and one nut.
- The shape of core rod varies depending on its size. Please confirm with the figure below.

[Parts Included]

- Wheel shaft

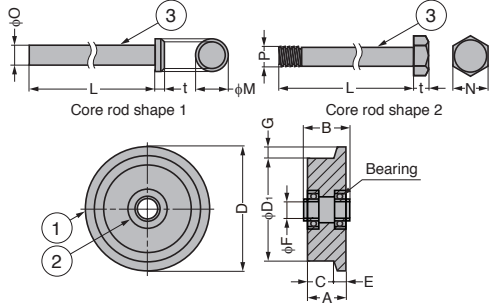

[Application Example]

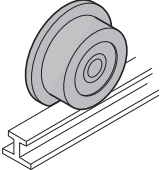

No.	Part Name	Material	Finish
①	Wheel	Ductile Cast Iron	Black Enamel Finish
②	Bearing	-	-
③	Core Rod	Steel (SWCH)	-

Item Name	D	D ₁	A	B	C	E	F	G	L	M	N	O	P	t	Weight (kg)	Core Rod Shape
GS-JC120-75L	90	75	32	35	24	8	13	7.5	75	19	-	12.9	-	4	0.9	1
GS-JC120-100L	120	100	36	39	26	10	16	10	100	24	-	15.9	-	5	1.7	1
GS-JC120-150L	150	130	43	48	33	10	20	10	100	-	30	-	M20	13	3.3	2
GS-JC120-200L	200	170	50	58	36.5	13.5	24	15	120	-	36	-	M24	15	6.5	2