

**Assembly examples**

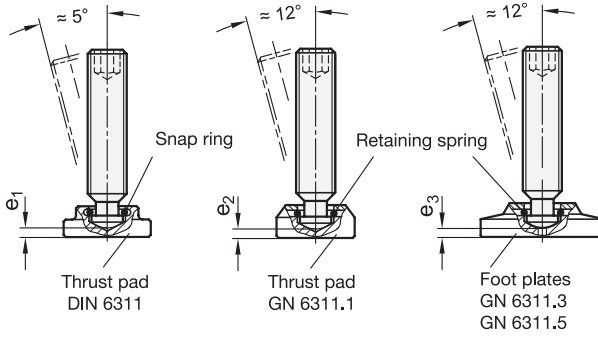

- 3 Type**
- SK** With thrust point, hardened (only in steel, blackened)
  - SKN** With thrust point, not hardened

1 2

**Steel, blackened / Stainless steel**

d <sub>1</sub>	Length l					d <sub>2</sub> h11	d <sub>3</sub>	e <sub>1</sub> ≈	e <sub>2</sub> ≈		e <sub>3</sub> ≈	A/F	z <sub>1</sub> ≈	z <sub>2</sub> ≈	
									Type A	Type P					
M 6	30	35	40	45	50	-	4,5	4	2,1	1,5	4,5	-	3	6	2,5
M 8	35	40	45	50	60	70	6	5,4	3	2,3	5,3	-	4	7,5	3
M 10	45	50	55	60	65	80	8	7,2	3,6	2,6	5,6	-	5	9	4,5
M 12	50	60	65	70	80	100	8	7,2	4,6	2,9	6,9	3,7	6	10	4,5
M 16	65	70	75	80	100	125	12	11	5,4	4,5	9,5	4	8	12	5
M 20	80	90	100	125	150	-	15,5	14,4	5,5	4,5	10,5	4,3	10	14	5,5

1 2

**Steel, zinc plated**

d <sub>1</sub>	Length l					d <sub>2</sub> h11	d <sub>3</sub>	e <sub>1</sub> ≈	e <sub>3</sub> ≈	A/F	z <sub>1</sub> ≈	z <sub>2</sub> ≈
M 10	45	55	65	80	-	8	7,2	3,6	-	5	9	4,5
M 12	50	60	70	80	100	8	7,2	4,6	3,7	6	10	4,5
M 16	65	70	80	100	125	12	11	5,4	4	8	12	5
M 20	90	100	125	150	-	15,5	14,4	5,5	4,3	10	14	5,5

**Specification**

- Steel Property class 5.8
  - Blackened —
  - Thrust point hardened (Type SK) —
  - Thrust point not hardened (Type SKN) —
  - Zinc plated, blue passivated **ZB**
  - Thrust point not hardened (Type SKN) —
- Stainless steel AISI 304 **NI**
  - Thrust point not hardened (Type SKN) —
- ISO Fundamental Tolerances → Page 2151
- Strength Values of Screws → Page 2152
- Stainless Steel Characteristics → Page 2166
- RoHS

4

**Information**

The thrust point of these screws DIN 6332 is designed to be used with or without the thrust pad for clamping.

The pin diameter of the grub screws is smaller than the core diameter of the thread, allowing them to be screwed in on the pin side.

The snap ring resp. snap spring of the thrust pad is a simple and quick method to connect the thrust pad to the grub screw.

How to order (Steel, blackened)

**DIN 6332-M12-60-SK**

- 1 d<sub>1</sub>
- 2 Length l
- 3 Type

How to order (Steel, zinc plated)

**DIN 6332-M16-80-SKN-ZB**

- 1 d<sub>1</sub>
- 2 l<sub>1</sub>
- 3 Type
- 4 Finish (Material)

3.1  
3.2  
3.3  
3.4  
3.5  
3.6  
3.7  
3.8  
3.9

