

# 旋轉扭矩鉸鏈GS-HG-S-75 型 孔徑 $\phi 75$ 型

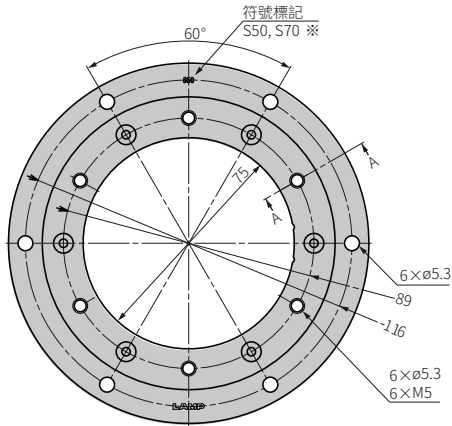

編號	零件名稱	材質	處理
①	旋轉片A	SUS430	亮光滾筒拋光
②	旋轉片B		
③	旋轉片C		
④	F板	磷青銅	-
⑤	套管	POM	-
⑥	碟簧	SUS	-
⑦	軸	SUS303	-



[安裝孔加工圖]

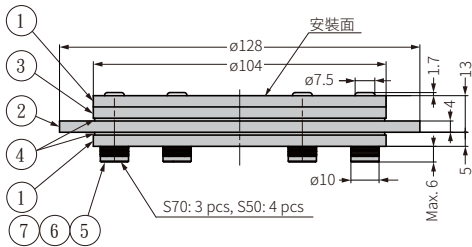
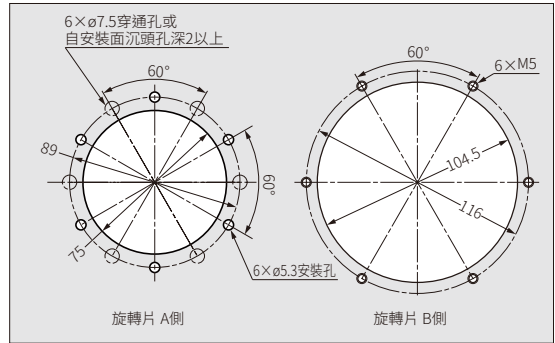

[安裝方向列]

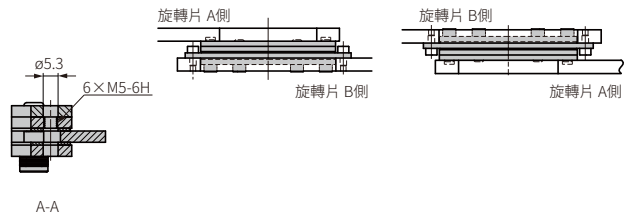

※ S50: HG-S50-75, S70: HG-S70-75.

品號	外徑	中心部孔徑	扭矩N · m	扭矩kgf · cm	質量(g)	盒(pcs)	箱(pcs)
GS-HG-S50-75	128	75	5.0 ± 20%	51.0 ± 20%	545	5	40
GS-HG-S70-75			7.0 ± 20%	71.4 ± 20%	575	5	40